



另行通知。



Trademark

SINSEGYE® is registered trademarks of Sinsegye. All other merchants Logos, service marks and trade names are the property of their respective owners.



Technical support and after-sales service

If you have any technical questions related to the product, please contact us at:

Service hotline: 400-013-2158

Get manuals and information

If you need manuals or other technical information, please send your request to:

Sales@sinsegye.com.cn

Legal Notices

@2022 Sinsegye All Rights Reserved

Sinsegye (Shenzhen) Computer System Co., Ltd. (hereinafter referred to as "Sinsegye") reserves the right to modify the product information and product specifications in this manual.

For any direct, indirect, special, incidental or consequential losses caused by the incorrect use of this manual or the product, Sinsegye shall not be liable for any direct, indirect, special, incidental or consequential losses.

Sinsegye owns the patents, copyrights and other intellectual property rights of this product and its software right. This product or any related parts may not be copied, manufactured, processed or used, directly or indirectly, without authorization.

Manual of SP7020/SP7022 IPC Type Industrial Intelligent Computer

PREFACE

Product introduction

The SP series IPC type industrial intelligent computer(hereinafter referred to as “iComputer”) is a series of X86 architecture PC-based industrial intelligent universal controllers launched by SINSEGYE. This model of iComputer integrates functions such as logic control, motion control, industrial vision and HMI, and has the characteristics of localization, integrated computing and control,high real-time performance, and scalability. In addition to providing rich interfaces, this product also supports I/O interface terminals and PCIE interface expansion modules for functional expansion, meeting complex industrial field application needs.

User manual and scope

This manual is specifically designed for trained and qualified technical personnel to install, operate, and maintain the equipment. Only professionals or trained and qualified personnel can install, replace, and repair this equipment.

Version change record

Version No.	Modification date	Description of changes
V1.0	2024-05	First version of basic information
V2.0	2024-010	Integrated information description of the first version
V2.1	2024-011	1. Add version change record 2. Alternation in product naming rules 3. Add the modification of Bios serial port mode

To obtain manual and other resources

This manual is not delivered with the product. Resort to the following channels for the electronic or paper version:

- Log in to SINSEGYE website, <https://www.sinsegye.com.cn> and download intended manual and other resources from the relevant information list.
- Obtain the manual and resources from the technology support party or sales agency.
- Search and follow SINSEGYE WeChat official account, and get the manual and other resources.

SAFETY PRECAUTIONS

Safety requirements

The equipment shall be used according to the instructions in this manual.

Safety signs

In order to ensure work safety, please comply with the safety signs posted on the equipment. Do not damage or peel off the safety signs. The safety signs are described as follows:

Safety Signs	Content Description
	<ul style="list-style-type: none">• Please read the safety manual and instructions carefully before using the equipment to avoid casualties or damage to the equipment!
	<ul style="list-style-type: none">• Pay attention to the high temperature label and grounding label on the surface of the equipment. Please ground the equipment and take measures against high temperature, otherwise there will be a risk of casualties or product damage!

Power supply requirements

1. DC12-28V;
2. Before you power the device, make sure that the power supply voltage meets the requirements of the device.

Routine maintenance

1. Do not open or disassemble the equipment randomly. The equipment should only be opened by professional maintenance personnel.
2. Before cleaning the equipment with a damp rag, unplug the power cord from the outlet. Do not use liquids or decontamination sprayers to clean the equipment.
3. In case not using the equipment for a long time, please turn off the computer normally and disconnect the power cord to avoid the equipment being damaged by the instantaneous voltage.
4. Prevent any liquid from flowing or spilling into the equipment to avoid short circuits or fires.

Operating environment

1. Please ensure that the equipment is placed on a reliable flat surface before installation, accidental dropping or overturning may cause damage to the equipment.
2. The openings in the enclosure of the equipment are for air convection and prevent the equipment from overheating, and forbid to cover or seal these openings.
3. Please do not use the equipment in a humid environment.

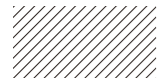

TABLE OF CONTENTS/

PREFACE

SAFETY PRECAUTIONS

1. PRODUCTION INFORMATION	01
1.1 Controller appearance	01
1.2 Controller interface	01
2. PRODUCT SPECIFICATION	03
3. MECHANICAL INSTALLATION	04
3.1. Installation precautions	04
3.2. Preparation before installation	04
3.3. Installation dimensions	05
4. ELECTRICAL INSTALLATION	06
4.1. Wiring recommendations	06
4.2. Communication interface wiring	07
4.3. Specifications of display interface	13
4.4. Specifications of display interface	15
4.5. Interface of button switch	15
5. PART III OPERATING INSTRUCTIONS	16
5.1 Operating system	16
5.2 Power on	17
5.3 Power off	17
5.4 Programming & Debugging	17

1. PRODUCTION INFORMATION

1.1 Controller appearance

SP7020

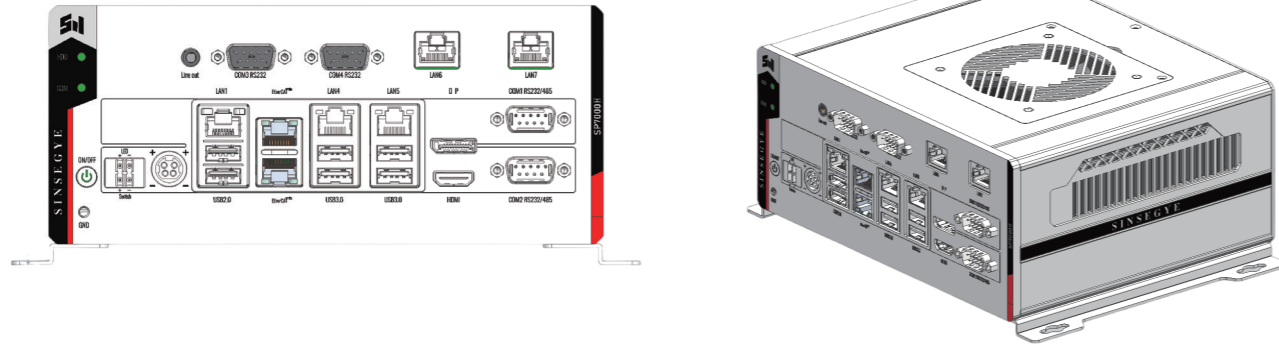

SP7022

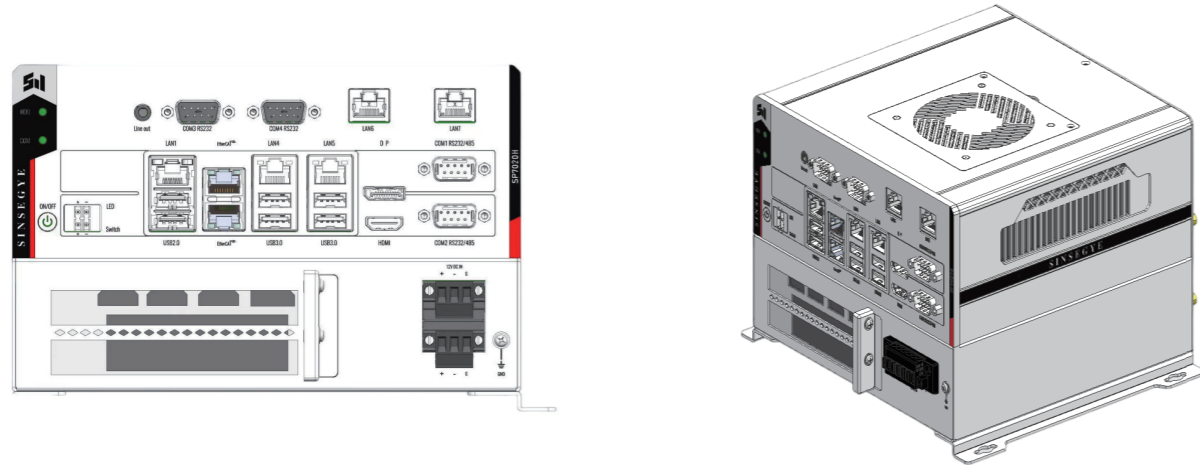

1.2 Controller interface

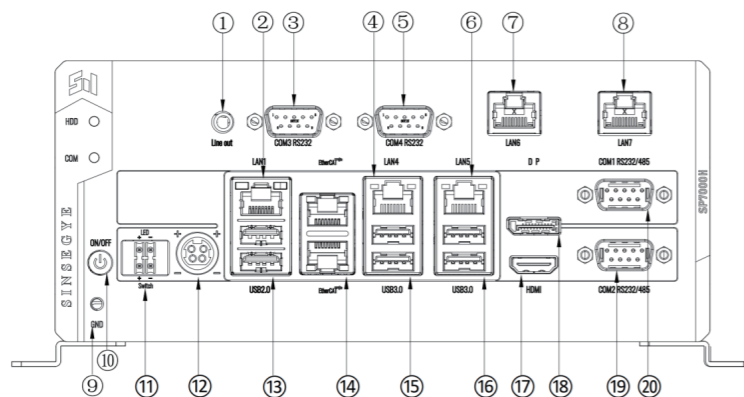

Serial number	Interface Name	Description
①	Mic in&Line out	---
②	LAN1	Gigabit Ethernet port,IPV4: 192.168.1.200 Subnet mask: 255.255.255.0
③	COM3	RS232 serial port
④	LAN4	Gigabit Ethernet port
⑤	COM4	RS232 serial port
⑥	LAN5	Gigabit Ethernet port
⑦	LAN6	Gigabit Ethernet port
⑧	LAN7	Gigabit Ethernet port
⑨	Grounding screw	M4 grounding screw
⑩	Power switch	System power on/off
⑪	SW switch	Remote power on signal
⑫	Power switch	220VAC power adapter, input 12V power supply
⑬	USB port	Type-A interface,USB2.0 protocol
⑭	Ethercat	Ethercat master station, network name:enp8s0,enp1s0
⑮	USB port	Type-A interface,USB3.0 protocol
⑯	USB port	Type-A interface,USB3.0 protocol
⑰	DP port	DP display interface
⑱	HDMI port	HDMI display interface
⑲	COM1	RS232/485/ serial port
⑳	COM2	RS232/485/ serial port

2. PRODUCT SPECIFICATION

Product name	SP7020	SP7022
Operating system	Linux+Windows10	
Processor	Intel Core I5-12400,2.5GHz,up to 4.4 GHz,TDP 65 W,6 cores 12 threads	
Memory	systemDDR4 3200MHz 16GB	
System hard disk	128GB SSD + 512G SSD	
Motion control capability	256 axes	
Axial performance	8 axes/250us 64 axes/500us	
LAN ethernet	7 channels	
Serial port	4*COM(2*RS485/RS232+2*RS232)	
USB port	4*USB 3.0+2*USB 2.0	
DIDO	Not support	
Display interface	HDMI+DP	
Power supply	DC 12V, matched with AC220V power adapter	
Switch	Button switch indicator	
SW terminal	4PIN terminal(switch + indicator)	
Line Out	1*line out	
Extension slot	Not support	1*PCIEX16+1*PCIEX4
Installation	Embedded	
Appearance dimension	208(W)*202(D)*89(H) mm	208(W)*202(D)*133(H) mm
Storage temperature	-20~70°C	
Operating temperature	-10~50°C	

3.MECHANICAL INSTALLATION

3.1 Installation precautions

Installation Considerations for Industrial Intelligent Computer(hereinafter referred to as "iComputer"):

- Before installation, make sure the product is powered off;
- Prevent the controller's housing, terminal strip, or connector from falling or being impacted to avoid damaging the controller;
- Do not disassemble the module, as this may damage the machine;
- Forbid to excessively tighten torque to avoid damage to the terminals and the machine;
- There should be air inlets and outlets on the left and right sides of the installation cabinet, and no wires can pass through the air inlets and outlets;
- The openings on the left and right sides of the iComputer are for ventilation, so do not block or cover them;
- The iComputer realizes heat dissipation through heat conduction by high-performance copper tube and large-area aluminum material. Be cautious to the high heat dissipation temperature at the air outlet.

3.2 Preparation before installation

3.2.1 Installation environment requirements

The iComputer should be installed on the basis of full consideration of operability, maintenance, and environmental resistance. Do not install the module in the following places.

- Places where the ambient temperature exceeds the range of -10°C~ +55°C;
- Places where the ambient humidity exceeds the range of 5%RH~ 95%RH;
- Places where the temperature changes drastically and condensation is generated;
- Places with corrosive gases and flammable gases;
- Places with a lot of conductive powders such as dust and iron powder, oil mist, salt, and organic solvents;
- Places exposed to direct sunlight;
- Places where strong electric and magnetic fields occur;
- Places where the body will be subjected to direct vibration and conductive impact.

3.2.2 Installation space requirements

In order to facilitate ventilation and module replacement, at least a certain amount of space should be reserved between the surrounding area of the module and the installation environment and surrounding components, as shown in the figure below.

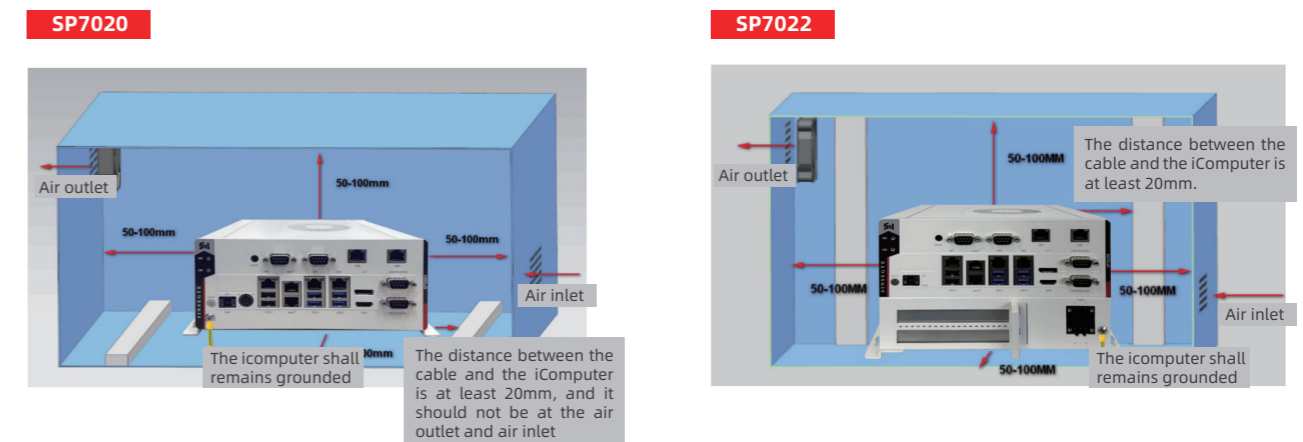

3.3 Installation dimensions

- Installation dimension(unit: mm)

SP7020

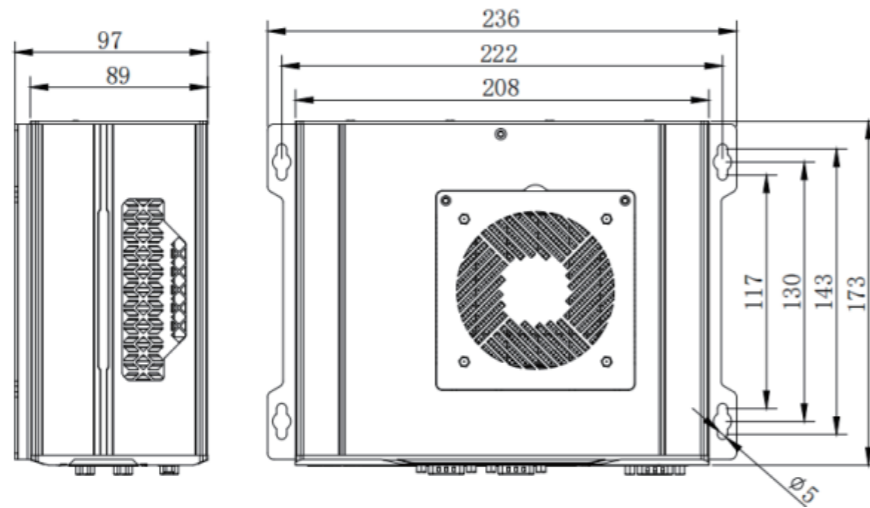

SP7022

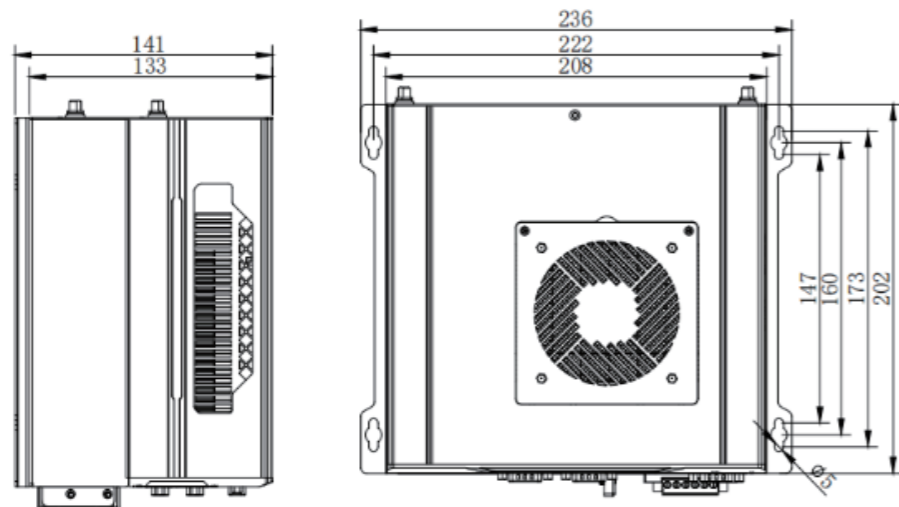

4. ELECTRICAL INSTALLATION

4.1 Wiring recommendations

4.1.1 Grounding requirements

A grounding point (⚡) is provided on the front ear of the industrial intelligence machine. Use the grounding wire as thick and short as possible (the wire length is less than 30cm) to ground the whole controller.

Shielded Cable Grounding

Shielded cables must be used for communication signals. The ground point shall be as close as possible to the module, so that the grounded cable is not affected by electromagnetic induction from the cable before grounding. For the bared shielding part of the shielded cable after the outer skin is peeled off, it should be grounded with a large area as much as possible to ensure good contact.

For welding PVC wires to the shielding part of shielded cables, grounding the front end will increase high-frequency impedance and weaken the shielding effect and such method should be avoided as much as possible. The shielded cables of communication signal cable need to be grounded at both ends.

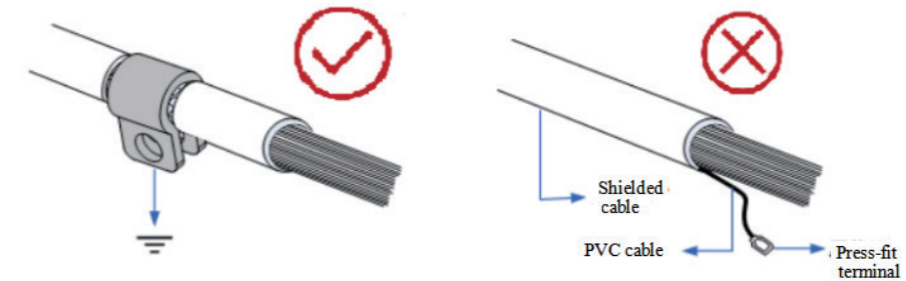

Schematic Diagram of Signal Cable Grounding 1

4.1.2 Wiring requirements

Low-voltage cables (<1KV) are generally divided into four categories, only the same type of cable can be put together to form a cable bundle. Different types of cables should be separated to avoid being crossed and overlapped. Right-angle crossing shall be available if necessary.

Serial No.	Category	Application object
1	Category 1	Ethernet port, EtherCAT network port
2	Category 2	Low-speed digital communication signals (RS232, RS485, etc.) and digital I/O signals
3	Category 3	Low-voltage AC power distribution line or DC power line (e.g. DC 24V power line for switching power supply output)
4	Category 4	Input and output cables, welding machine cables, power converter power cables

Different types of cables need to be spaced at a certain distance, and for cables whose length is lower than 30 meters, the minimum allowable spacing is shown in the figure below.

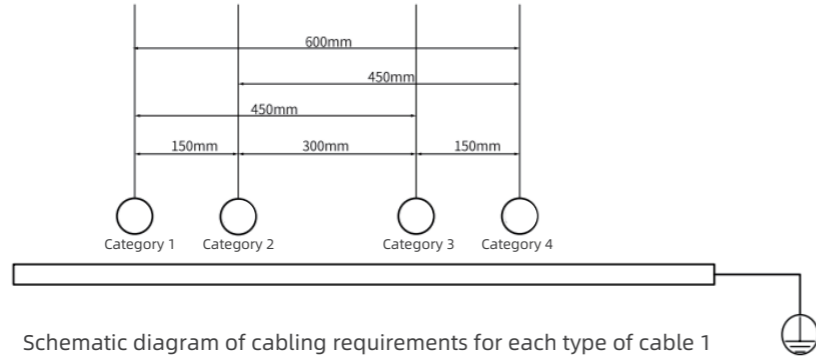

Notes

- When the length of the cable horizontal routing increases, the spacing should be increased appropriately;
- In addition to maintaining the spacing, it is also possible to add multiple shielding plates between different types of cables to achieve shielding. To reduce cross-interference, all cables should be routed as close as possible to the structural components that are grounding connected to the cabinet, such as the cabinet's assembly plates or brackets.

4.2 Communication interface wiring

4.2.1 Serial communication specifications

COM1&COM2 support RS232 and RS485 protocols. COM3&COM4 support RS232 protocol.

Description

By default, the serial ports are on the real-time side and do not support virtualization.

Communication interface diagram

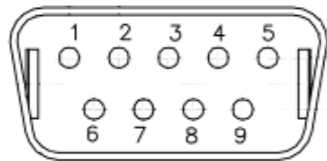

COM1/COM2 RS232/485 communication interface definition

Interface	Signal name	Interface	Signal name
1	COM1_DCD#/RS485-	6	COM1_DSR#
2	COM1_RXD/RS485+	7	COM1_RTS#
3	COM1_TXD	8	COM1_CTS#
4	COM1_DTR#	9	N/C
5	GND	-	-

COM3/COM4 RS232 communication interface definition

Interface	Signal name	Interface	Signal name
1	-	6	-
2	RXD	7	-
3	TXD	8	-
4	-	9	-
5	GND	-	-

DI input specifications

Item	Specification
Quantity of channels	4
Baud rate	4.8K,9.6K,19.2K,38.4K,57.6K,115.2K
Maximum number of slave sites	31
Support protocols	Modbus RTU protocol and free protocol
Isolation method	Isolation

RS485 bus wiring instructions

Notes:

At the time of wiring, forbid to bundle the extending cable with power lines (high voltage, high current) and other cables that transmit strong interference signals. Extending cable should be routed separately and avoid horizontal routing. Recommend to use cables and adapter boards for connection and select shielded cables as expansion cables to improve anti-interference capabilities.

It is recommended to use shielded twisted pair cables to connect RS485 bus. 485+ and 485- shall be connected with twisted pair cables; Only 120Ω termination matching resistors are connected at each end of the bus to prevent signal reflection; The reference ground of all node 485 signals is connected together; A maximum of 32 nodes can be connected, and the distance between the branches of each node should be less than 3 meters.

RS232 communication specifications

Item	Specification
Number of channels	2
Baud rate	4.8K,9.6K,19.2K,38.4K,57.6K,115.2K
Maximum number of slave sites	1
Support protocols	Modbus RTU protocol and free protocol
Isolation method	Isolation

4.2.2 Modify serial communication mode

In BIOS, COM1 and COM2 can be adjusted to RS0232 mode or RS-485 mode.

Operation procedures

- Connect the USB keyboard, press the Delete key to enter BIOS after booting up. Move the cursor keys to select the "Advanced" option and enter "Super IO Configuration".

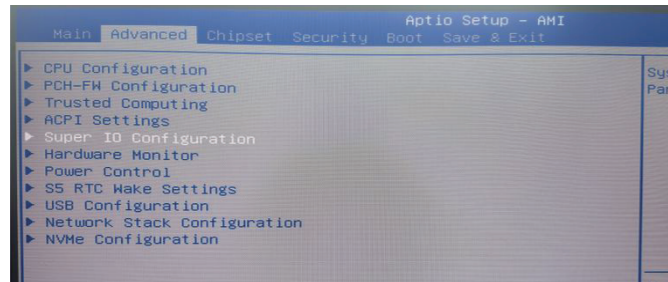

- Enter "COM1" to adjust COM1 port mode.

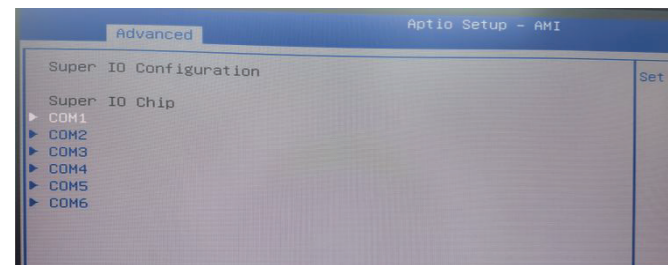

- In the "Change Settings", adjust "RS-232" or "RS-485" mode. As shown in the figure below, the RS-232 mode can be adjusted to RS-485 mode.
- The adjustment steps for COM2 mode are the same as those for COM1. After adjustment, press F4 and keep exiting.

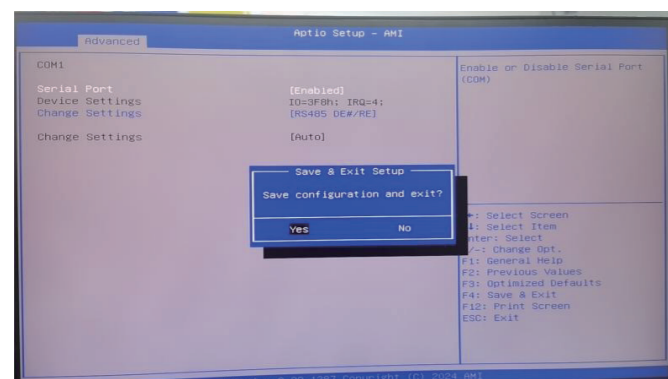









4.2.3 Network port communication specifications

This series of network ports can be used for Linux and Windows distribution and ring network setting through the configuration software.

Network port	Function
LAN1	Debugging network port, default IP address: 192.168.1.200
Ethercat	Ethercat master network port
Ethercat	Ethercat master network port
LAN4	Windows network port
LAN5	Windows network port
LAN6	Windows network port
LAN7	Windows network port

Definition of network port indicator

Indicator	Function	Color	Status	Description
	A: Link/Act	Yellow		Remain OFF: Not linked
				Blink: Linked and sending/receiving data
				Remain ON: Linked
	B: Speed	Green		Remain OFF: Not connected
				Blink: 100/1000Mbps connection
				Remain ON: 1000Mbps connection

4.2.4 EtherCAT communication specifications

EtherCAT specification

Network port	Function
Number of channels	1
Communication protocols	EtherCAT Protocol
Support services	COE(PDO,SDO)
Synchronization mode	Servo: DC - Distributed Clock IO: Input-output synchronization
Physical layer	100BASE-TX
Baud rate	100Mbit/s
Duplex mode	Full-duplex
Topology	Linear topology
Transmission medium	RJ45 network cable
Transmission distance	The two nodes are less than 100m
EtherCAT frame length	44 bytes ~ 1486 bytes
Process data	A single Ethernet frame can be up to 1486 bytes
Jitter between two slaves	<1µm
Auto-scan function	Support

4.2.5 Communication cable connection requirements

Communication has strict requirements for communication cables, and it is required to use super-Category 5 and above shielded network cables, and the requirements are as follows.

Cable requirements

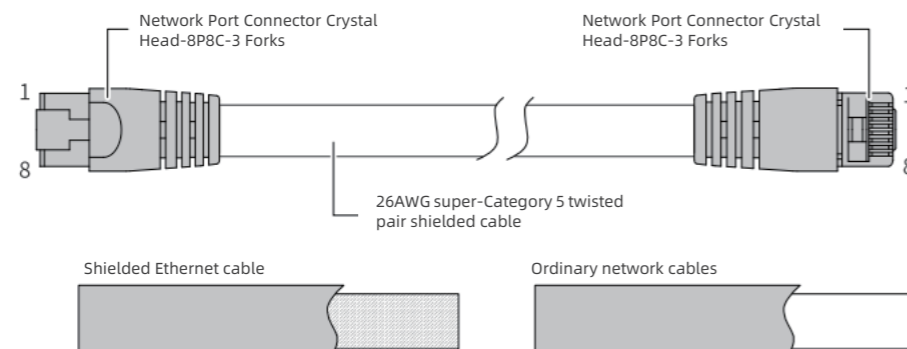

Pin	Signal (Ethernet 100Mbps)	Signal direction	Signal description
1	TD+	Output	Data transmission+
2	TD-	Output	Data transmission-
3	RD+	Input	Data reception+
4	-(DC+)	-(Bidirectional)	Not used (Data C+)
5	-(DC-)	-(Bidirectional)	Not used (Data C-)
6	RD-	Input	Data reception-
7	-(DD+)	-(Bidirectional)	Not used (data D+)
8	-(DD-)	-(Bidirectional)	Not used (data D-)

Note

At 1000Mbps and 100Mbps Ethernet baud rates, the definitions of pins 4, 5, 7, and 8 are not the same.

Length requirements

FastEthernet technology confirms that when the EtherCAT bus is adopted, the length of the cable between devices should not exceed 100 meters, and more than this length will attenuate the signal and affect normal communication

Technical requirements

100% conduction test, no short circuit, open circuit, misalignment or poor contact. The EtherCAT bus uses shielded cables for network data transmission, and the following network cables are recommended:

Item	Specification
Cable type	Flexible crossover cable, S-FTP, super-Category 5
Meet standards	EIA/TIA568A, EN50173, ISO/IEC11801 EIA/TI Abulletin TSB, EIA/TIA SB40-A&TSB36
Wire section	26AWG
Wire type	Twisted pair cable
Pairs	4

The following table shows the relationship between the number of EtherCAT bus nodes, the cable impedance, and the transmission distance:

Maximum number of nodes	Cable impedance	16	32	64
Transmission distance	88 ohms/km	215m	200m	170m
	93 ohms/km	205m	185m	160m
	157 ohms/km	120m	110m	95m

4.3 Specifications of display interface

4.3.1 DP interface specifications

The iComputer adopts standard DP display interface, and the main specifications are as follows:

Item	Specification
Signal type	Digital DP1.2
Highest resolution	1920x1080@60Hz
Whether hot plug is supported?	Support

DP terminal pin is defined as follows:

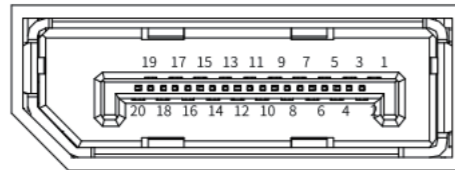

Serial No.	Description	Functions
1	ML_Lane 0 (p)	Main link channel 0: differential signal
2	GND	-
3	ML_Lane 0 (n)	Main link channel 0: differential signal
4	ML_Lane 1 (p)	Main link channel 1: differential signal
5	GND	-
6	ML_Lane 1 (n)	Main link channel 1: differential signal
7	ML_Lane 2 (p)	Main link channel 2: differential signal
8	GND	-
9	ML_Lane 2 (n)	Main link channel 2: differential signal
10	ML_Lane 3 (p)	Main link channel 3: differential signal
11	GND	-
12	ML_Lane 3 (n)	Main link channel 3: differential signal
13	GND	-
14	GND	-
15	AUX_CH (p)	Auxiliary channel: differential signal
16	GND	-
17	AUX_CH (n)	Auxiliary channel: differential signal
18	Hot Plug	Hot plug detection
19	DP_PWR Return	Interface power feedback signal
20	DP_PWR	Power supply:+3.3V

4.3.2 HDMI interface specifications

The iComputer adopts standard HDMI display interface, and the main specifications are as follows:

Item	Specification
Signal type	Digital HDMI
Highest resolution	1080P
Whether hot plug is supported?	Support

The HDMI terminal pin is defined as follows:

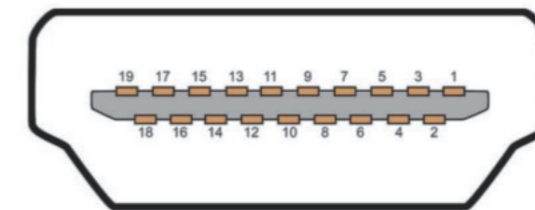

Product name	Signal
1	TMDS Date 2+
2	TMDS data 2 masked
3	TMDS data 2
4	TMDS data 1+
5	TMDS data 1 masked
6	TMDS Data 1-
7	TMDS data 0+
8	TMDS data 0 masked
9	TMDS Data 0-
10	TMDS Clock+
11	TMDS clock masked
12	TMDS clock
13	CEC
14	HEC data
15	SCL (DDC Serial Clock)
16	SDA (DDC Serial Data Line)
17	DDC/CEC/HEC floor
18	+5V Supply (50mA Max)
19	Hot plug detection (1.3) / HEC Data + (1.4)

4.4 Specifications of display interface

The iComputer has a total of 4 USB ports, 2 USB3.0 ports, and 2 USB2.0 ports, as shown in the following figure:

Item	USB3.0	USB2.0
Maximum communication rate	5.0Gbps	480Mbps
5V maximum output current	900mA	500mA
Maximum communication distance	3m	5m
Isolation or not?	Not	Not

The interface format is shown as the following figure

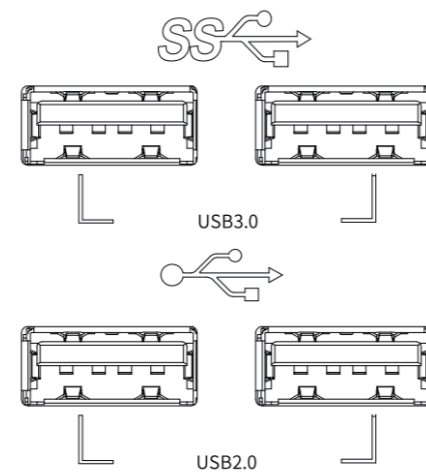

Note

- Please choose industrial-grade USB equipment for industrial applications to ensure reliability.
- Long-term connections are not recommended for USB devices. Besides, comply with wiring standards so as to prevent the equipment from being intervened and ensure favorable communication performance.
- In case of irrevocable interference, magnetic rings can be added at both ends of the communication cable to filter out interface and improve anti-interference performance.

4.5 Interface of button switch

ON/OFF button switch specifications

Item	Status indicator color when iComputer is powered on
When iComputer is not turned on	OFF
When iComputer is turned on	Blue

ON/OFF button switch is shown in the figure below:



5. PART III OPERATING INSTRUCTIONS

5.1 Operating system

MetaOS

The MetaOS dual operating system embeds a real-time kernel in the Linux kernel to form a stable and isolated dual-kernel architecture, building a real-time domain based on the real-time kernel and a non-real-time domain based on the Linux kernel. The real-time domain specializes in handling tasks that require a certain incident response time, achieves hard real-time, and provides strict real-time assurance for tasks, while non-real-time domains provide rich operating system services for other tasks. Such two domains operate independently and do not interfere with each other. The SP70 series iComputers integrate traditional upper industrial computer and lower PLC, running real-time control tasks and data acquisition tasks in the real-time domain of the iComputer, and deploy and apply upper-level programs in the non-real-time domain.

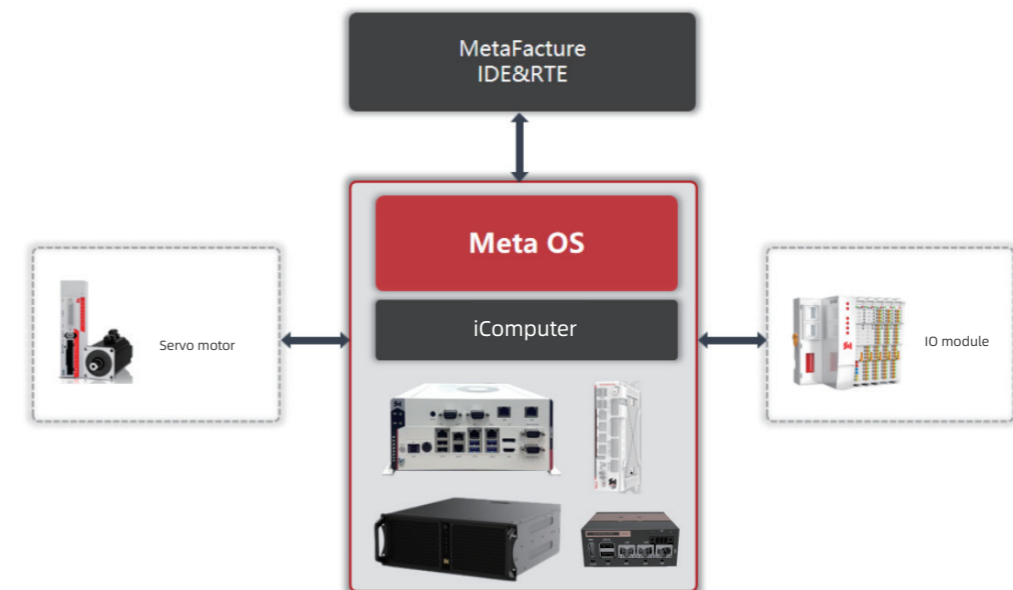
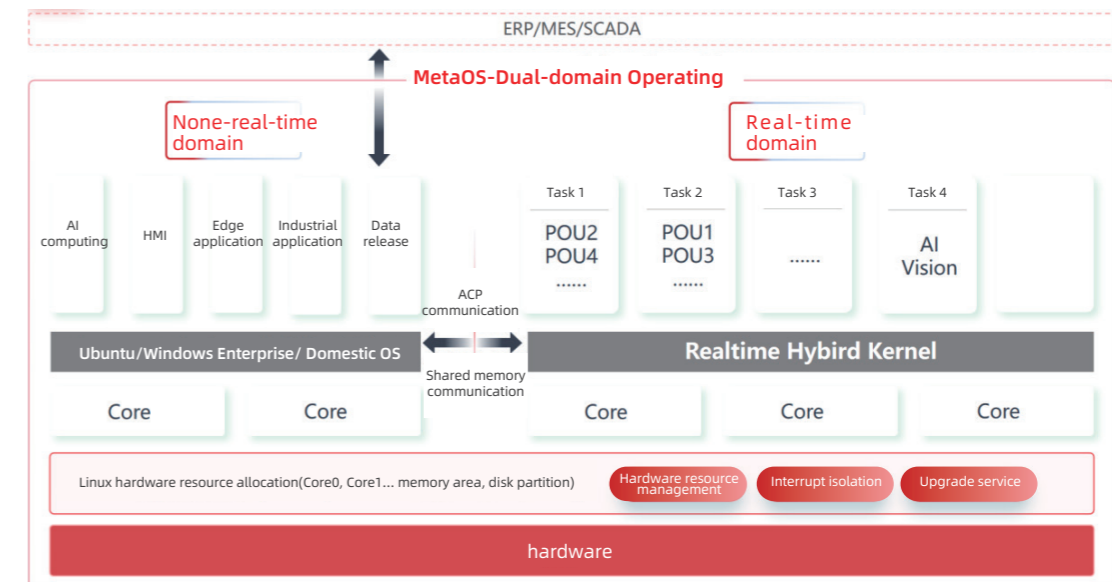

5.2 Power on

Before turning on the iComputer, make sure they are fully configured. After 50~60 seconds since the equipment is powered on, the equipment enters the operation mode.

Please follow the steps below for the first startup:

- After installing the iComputer, connect the display device, and turn on the power supply;
- Automatically log in for the first time and enter the operating system desktop, as shown in the figure below;

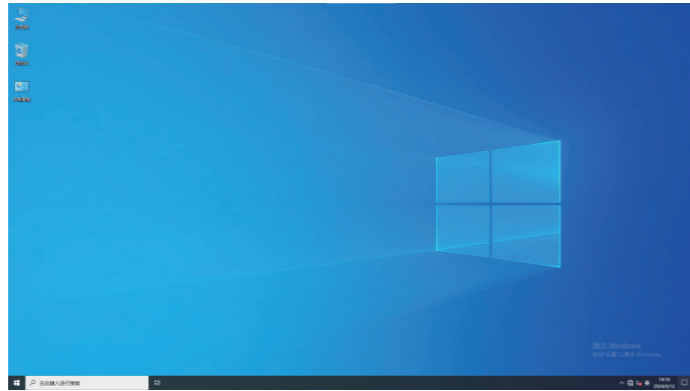

Note

- The default ex-factory enterprise version of Windows is not activated

5.3 Power off

Please follow the steps below to turn off the iComputer

- Properly stop all running programs.
- Shut down the operating system.
- Turn off the external power to shut down the iComputer.

5.4 Programming & Debugging

5.4.1 Add device

- Download the corresponding Sinsegye device description file to the local.
- In MetaFacture, click [Tools] > [Device repository...] in the menu bar;



- Click [Install (I)...]

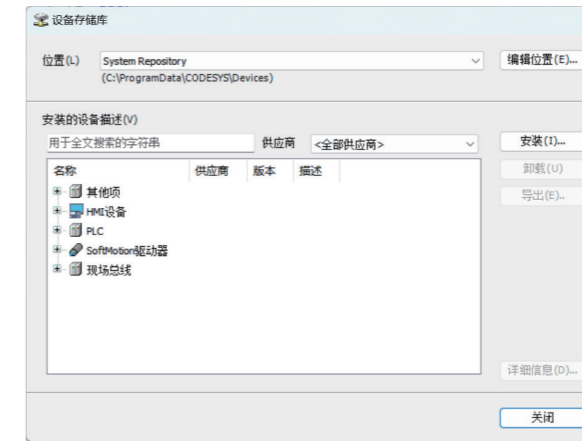

- Find the directory where the device description file is stored, select [Auto Detect] as the file detection type in the lower right corner, select the device description file of SP7020 iComputers, "Sinsegye-x86_64-Linux-SM-CNC.devdesc.xml", and SRC8200 device description file, "EcatTerminal-SRC_V1.09_ENUM_2.xml", and click [Open], showing the equipment has been installed.

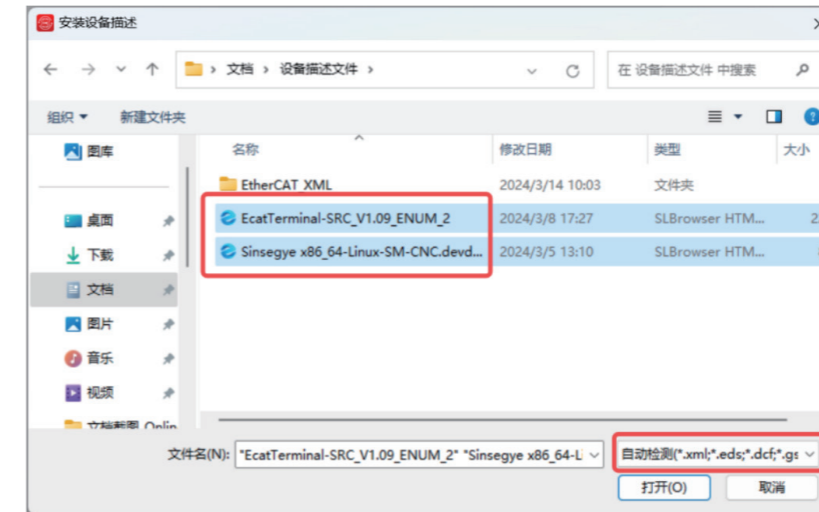

- Click [Close] to close the dialog box.

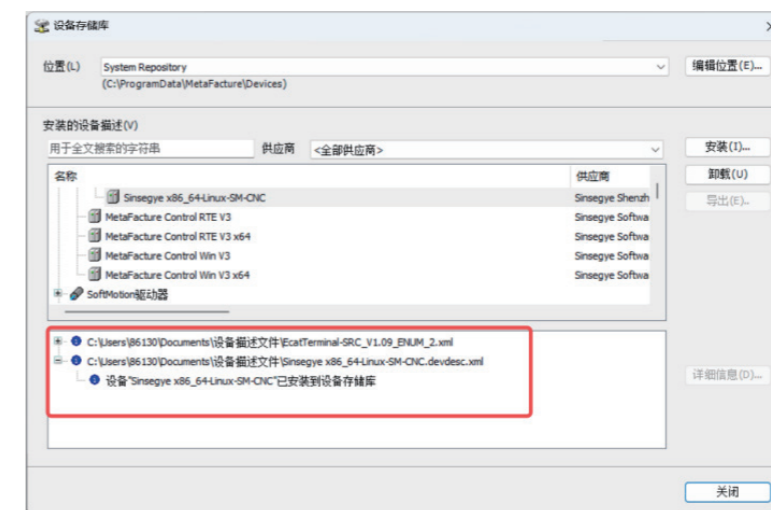

5.4.2 Connect the device

- Open [New Project] panel, select [Project] for type, select [Standard Project] for the template, and enter the self-defined project name and the location where the project is saved, and click [OK].

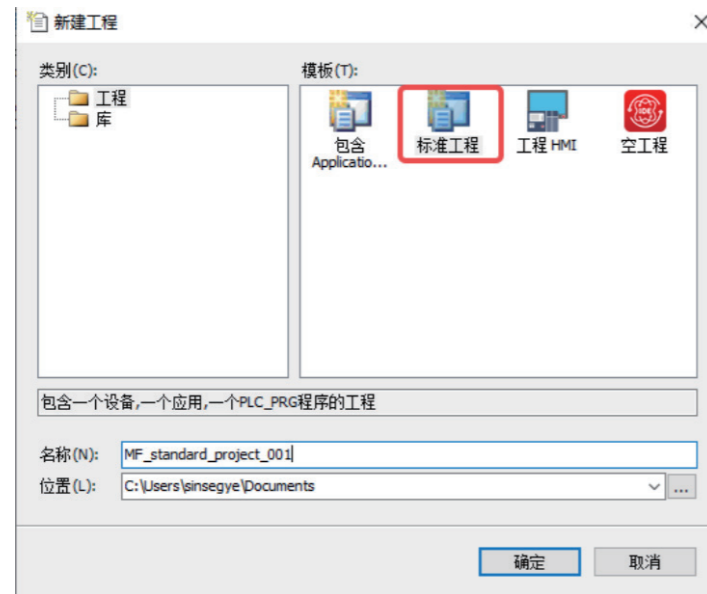

- Select a PLC in [Device (D)] list (if not finding the corresponding PLC, please confirm that the device has been installed correctly, please refer to "Adding a Device" for specific steps), and select a commonly used programming language in the [PLC_PRG (P)] drop-down list, and click [OK].

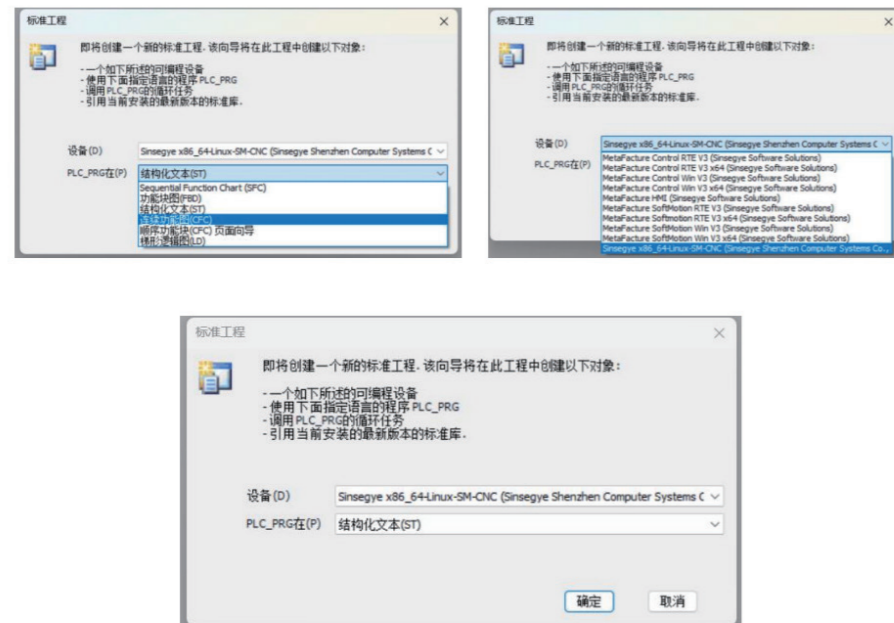

- In MetaFactory, double click [Device] in the device window to open the Device page. Make sure that the iComputer is connected to the network and is on the same network segment as the computer with MetaFactory installed.

Method 1: Enter the IP address of the PLC and press [Enter]

Method 2: Click [Scan Network] and select the corresponding device from the pop-up scan results

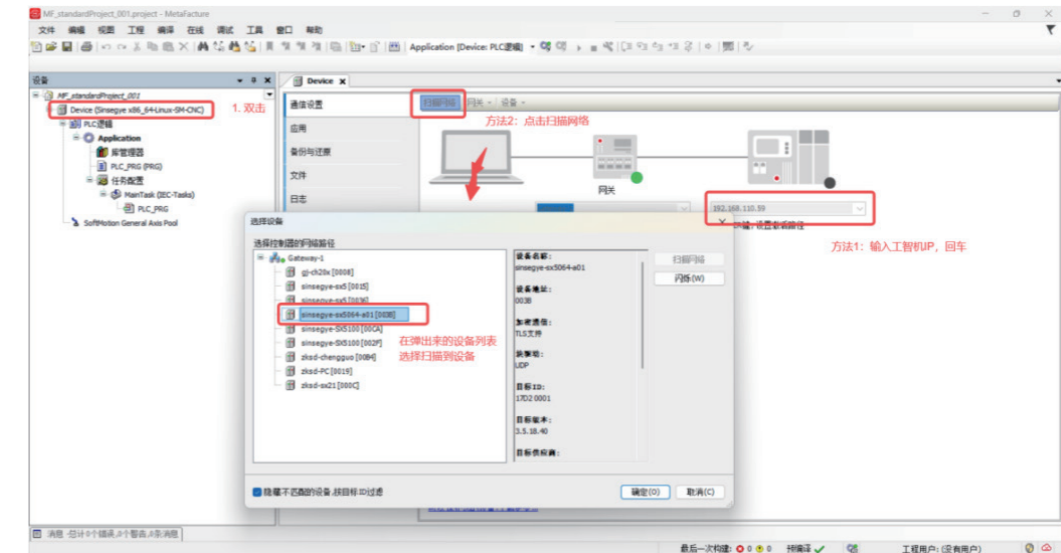

Note

The default IP address of the debug port of the iComputer is 192.168.1.200

- (Optional) After the PLC is connected, you can rename the device to facilitate future scanning of the device, click [Equipment] > [Rename Active Device], enter a user-defined device name, and click [OK].

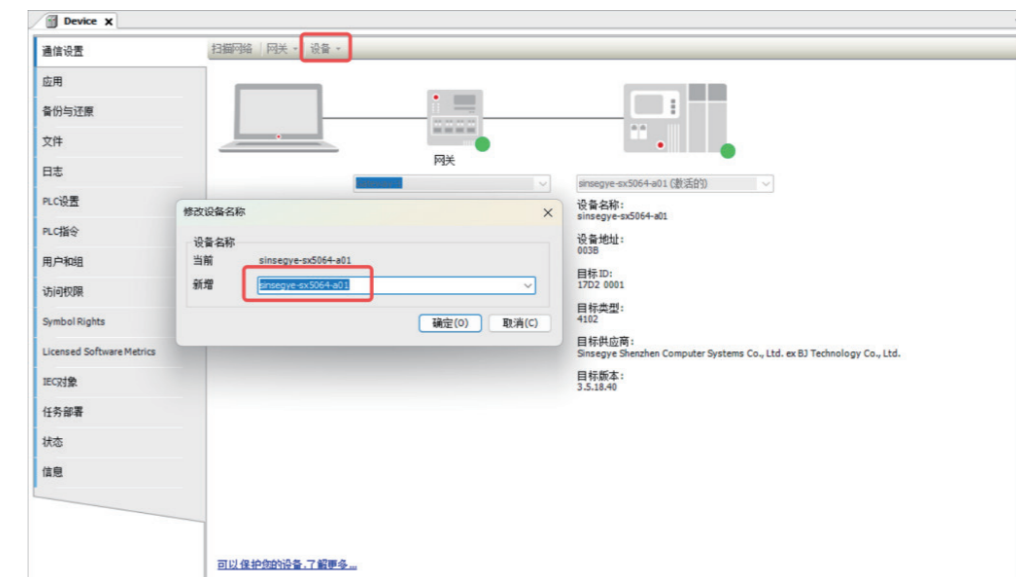

5.4.3 Programming

For more information about the programming and debugging process, see MetaFactory Basic Operations.