



另行通知



Trademark

SINSEGYE® is registered trademarks of Sinsegye. All other merchants Logos, service marks and trade names are the property of their respective owners.



Technical support and after-sales service

If you have any technical questions related to the product, please contact us at:

Service hotline: 400-013-2158

Get manuals and information

If you need manuals or other technical information, please send your request to:

Sales@sinsegye.com.cn

Legal Notices

@2022 Sinsegye All Rights Reserved

Sinsegye (Shenzhen) Computer System Co., Ltd. (hereinafter referred to as "Sinsegye") reserves the right to modify the product information and product specifications in this manual.

For any direct, indirect, special, incidental or consequential losses caused by the incorrect use of this manual or the product, Sinsegye shall not be liable for any direct, indirect, special, incidental or consequential losses.

Sinsegye owns the patents, copyrights and other intellectual property rights of this product and its software right. This product or any related parts may not be copied, manufactured, processed or used, directly or indirectly, without authorization.

USER MANUAL

SX Series Embedded PC

CONTENT/

| | | | |
|---------------------------------------|----|--|----|
| PREFACE | 01 | 5. INSTALLATION OF EMBEDDED INDUSTRIAL INTELLIGENT COMPUTER | 13 |
| 1. PRODUCT INTRODUCTION | 04 | 5.1 Precautions before Installation | 13 |
| 1.1 Product Introduction | 04 | 5.2 Requirements for Installation Environment | 13 |
| 1.2 Product Nameplate Information | 04 | 5.3 Installation Method | 13 |
| 1.3 General Specifications of Product | 05 | 6. ELECTRICAL INSTALLATION | 14 |
| 1.4 Ordering information of Product | 06 | 6.1 On-site Wiring Requirements | 14 |
| 2. SX51xx SERIES | 07 | 6.1.1 Grounding Requirements | 14 |
| 2.1 Product Overview | 07 | 6.1.2 Shielded Cable Grounding | 14 |
| 2.2 Panel Description | 07 | 6.2 Power Wiring Instructions | 14 |
| 2.3 Definition of Indicators | 08 | 6.3 Interface Wiring Instructions | 15 |
| 2.4 Structural Dimension Diagram | 08 | 6.3.1 Network Port Description | 15 |
| 3. SX21xx SERIES | 09 | 6.3.2 USB Description | 16 |
| 3.1 Product Overview | 09 | 6.3.3 HDMI Description | 16 |
| 3.2 Panel Description | 09 | 6.3.4 Serial /CAN =Description | 17 |
| 3.3 Definition of indicators | 10 | 7. PROGRAMMING AND DEBUGGING | 18 |
| 3.4 Structural Dimension Diagram | 10 | 8. REPAIRING AND MAINTENANCE | 19 |
| 4. SX58xx SERIES | 11 | 8.1 Notes | 19 |
| 4.1 Product Overview | 11 | 8.2 Items Subject to Regular Inspection | 19 |
| 4.2 Panel Discription | 11 | 8.3 Maintainable Components | 20 |
| 4.3 Definition of Indicators | 12 | 8.3.1 Replace Battery/CF Card | 20 |
| 4.4 Structural Dimension Diagram | 12 | 8.3.2 Replace Fan | 21 |
| 4.5 Expansion Module Description | 12 | 8.4 Storage and Waste Recycling | 21 |
| 4.5.1 Local IO modules | 12 | | |

PREFACE

Users and Scope of Manual

This manual is specifically designed for trained and qualified technical personnel to install, operate, and maintain equipment. Only professionals or trained and qualified personnel can install, replace, and repair this equipment.

Version Record

| Version No. | Revision date | Description of revision |
|-------------|---------------|---------------------------------------|
| V1.0 | 2023-05 | Collect and prepare the first version |
| V1.1 | 2024-07 | Add product models |
| V1.2 | 2024-08 | Add product model SX58xx |

Acquisition Methods of Manual and Resource

This manual is not shipped with the product. Resort to the following channels to get electronic or paper version of instruction:

- Log in to the official website of the company, <https://www.sinsegye.com.cn>, to download this manual from the relevant information list;
- Get the manual from the technical support or sales agency;
- Search the manual in WeChat official account of SINSEGYE.

Safety Statement

Before using this product, please read the manual and correctly understand the relevant information on safety precautions. Failing to comply with safety precautions may result in personnel casualties or equipment damage.

The “Danger”, “Warning”, “Caution”, and “Notice” in the manual do not represent all the safety precautions that should be followed, but only serve as a supplement to all safety precautions.

This product should be used in an environment that meets the design specifications, otherwise malfunctions will arise. Functional abnormalities or component damage caused by failure to comply with relevant regulations are not within the scope of product quality assurance.

Safety Precautions

There are four types of safety tips in this manual:

⚠️ DANGER

Indicates an imminent hazardous situation that, if not avoided, will result in serious injury or death.

⚠️ CAUTION

Should be paid to potential hazardous situations. Failure to avoid them may result in mild or moderate injuries, or equipment damage.

- When using this product, please be sure to check whether the appearance of the product is in good condition, and whether there is any cover according to the regulation. The illustrations of the products in this manual are sometimes used to showcase the details of the product.
- The product figure is intended for illustration and may differ slightly from the product shipped finally. Please refer to the actual ordered product. Product upgrades, iterations, and modifications are subject to change without prior notice.
- Please wear the necessary protective equipment or take other safety measures to protect personal safety when operating the equipment.

1) Safety tips for unpacking inspection

- Do not install the product if water ingress, missing or damaged components are found inside the product at the time of unpacking!
- Do not install any product that shows signs of damage, rust, or use!
- Do not install it if the packing list does not match the product name!
- Before opening the packaging box, please check whether the outer packaging of the equipment is intact
- Please open the packaging orderly, and do not forcefully tap.

2) Safety tips for storage and transportation

- When the product is lifted by lifting equipment, no personnel are allowed to stand or stay below the product.
- Please lift the product steadily and uniformly, to protect the product from vibration, impact, or flipping. Besides, forbidding to keep the product in a lifted state for a long time, otherwise there is a risk of personal injury or product damage!
- Be sure to lift and place the product gently and pay attention to objects under your feet to prevent tripping or falling, otherwise there is a risk of injury or product damage!
- When handling products by hand, please be sure to firmly grasp the product shell to avoid the parts of the product falling off, otherwise there is a risk of injury and equipment damage!
- Follow the storage and transportation conditions required by the product, otherwise there is a risk of product damage.
- Forbid storing or transporting the product in places with water splashes, direct sunlight, strong electric fields, strong magnetic fields, strong vibrations, etc.
- Not to store the product for more than 3 months. Stricter protection and necessary inspections are necessary for a longer period of storage.
- It is strictly prohibited to transport this product with equipment or items that may affect or damage it.

3) Safety tips for installation process

- Only professionals who have received training in electrical equipment and possess electrical knowledge can operate it. Non-professionals are strictly prohibited from operation!
- Please read the product manual and safety precautions carefully before installation!
- Do not install this product in places with strong electric fields or electromagnetic interference!
- Before installation, please ensure that the mechanical strength of the installation location is high enough to support the equipment's weight, otherwise it may cause mechanical danger.
- Do not wear loose clothing or accessories during installation, as there may be a risk of electric shock!
- When installing the product in a closed environment (such as a cabinet or chassis), it is necessary to meet requirements for installation environment, otherwise it may cause the product to overheat or catch fire.
- It is prohibited to modify this product!
- When installing equipment with strong electromagnetic interference such as transformers, please install shielding protection devices!
- During installation, prevent foreign objects such as metal shavings, oil, and water from entering the product during drilling, which may cause product failure.

⚠️ WARNING

Indicates a potential hazardous situation that, if not avoided, may result in serious injury or death.

NOTICE

Indicates a potential danger situation that, if not avoided, may only result in equipment damage.

4) Safety tips for equipment wiring

- Only professional personnel are allowed to install, maintain or inspect equipment, perform wiring, or replace components!
- Before wiring, please cut off the power supply of all devices. Release residual voltage and ensure safe voltage to avoid electric shock.
- Not perform wiring, remove the product cover, or touch the circuit board while cutting off power supply to avoid electric shock.
- Ensure that the equipment and products are well grounded, otherwise there may be a risk of electric shock and real-time performance cannot be guaranteed.
- It is strictly prohibited to connect the input power supply to the output terminal of the product, to protect equipment from damaging or fire.
- It is strictly prohibited to reversely connect the power supply. Please follow the product instructions for wiring, otherwise it may cause equipment damage.
- The cables used for wiring must meet the corresponding requirements for wire diameter and shielding. The shielding layer of shielded cables must be reliably grounded at one end!
- Please tighten the terminal screws according to the tightening torque specified in the manual to avoid insufficient or excessive tightening torque.
- After the wiring is completed, please ensure that all cables are wired correctly and there are no screws, washers, or bare cables inside the product.

5) Safety tips for equipment powered-on

- Before powering the equipment, please confirm whether the power of the supply matches the power of the equipment, to avoid product damage or fire hazards.
- Before powering the equipment, please confirm again whether the power supply meets the product requirements and whether the wiring is correct.
- It is strictly prohibited to open the product protective cover, touch any wiring terminals of the product, or disassemble any device or component of the product while it is powered on, otherwise there is a risk of electric shock!
- Before powering on the product, it is necessary to ensure that there are no personnel around the product, motor, and machinery, otherwise it may cause injury or death to personnel.

6) Safety tips for equipment operation

- Non-professionals are strictly prohibited from powering on the equipment for operation, otherwise there may be a risk of injury or death to personnel!
- It is strictly prohibited to touch any wiring terminals of the equipment, disassemble any devices or components of the equipment and products in operation, otherwise there is a risk of electric shock!
- During operation, avoid other items or metal objects falling into the equipment, otherwise it may cause fire or product damage!

7) Safety tips for equipment maintenance

- Non-professionals are strictly prohibited from installing, maintaining, or inspecting the equipment, performing wiring or replacing components of the equipment!
- It is strictly prohibited to maintain the equipment while it is powered on, to avoid the risk of electric shock!
- After cutting off the power to all devices, please release the induced voltage!
- Please inspect and maintain the equipment on a daily and regular basis in accordance with equipment inspection and maintenance requirements, and keep maintenance records.

8) Safety tips for equipment repair

- Non-professionals are strictly prohibited from installing, maintaining, or inspecting the equipment, performing wiring or replacing components of the equipment!
- It is prohibited to maintain the equipment maintenance powered on, to avoid electric shock.
- Maintain equipment according to warranty agreement.
- To replace components, follow the instructions for replacing vulnerable parts of the product.

9) Safety tips for equipment repair

- Scrapped equipment should be processed and recycled according to industrial waste disposal standards to avoid environmental pollution.

1.Product Introduction

1.1.Product Introduction

SX series of industrial intelligent computers is an embedded PC-based intelligent universal controller launched by SINS-EGYE. The SX series of intelligent computers integrates many functions such as logic control, motion control, industrial vision, and configuration display, and are characterized by localization, computing and control, high real-time performance, and scalability. In addition to providing rich interfaces, this product also supports serial expansion modules for functional expansion, meeting various complex industrial field application needs.

1.2.Product Nameplate Information

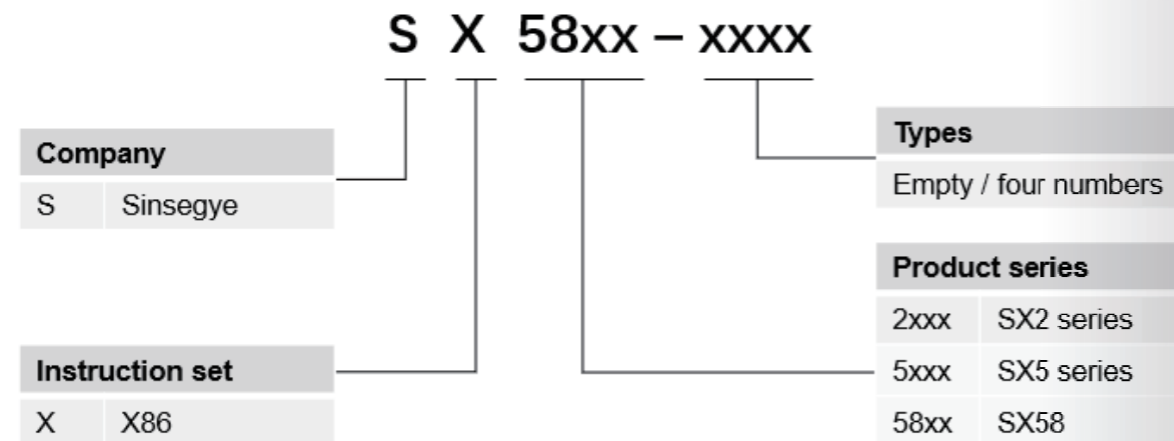

1.3.General Specifications of Product

| | SX21xx | SX51xx | SX58xx | |
|------------------------------------|--|---|-------------------------------|------------------------------|
| Main system | CPU | Hygon 3 series | Intel Atom® | Intel Celeron® |
| | Memory (G) | 16 | 4/8 | 4 |
| | Storage | Default 256GB, expandable 1TB | Default 128GB, expandable 1TB | Default 64GB, expandable 1TB |
| Hardware interface | Network port | 4 | 2/4 | 2 |
| | USB | 4 | 2 | 2 |
| | Serial port | 1*RS232/422/485 | | |
| | CAN | 1 | | |
| | HDMI | 1 | | |
| software interface | Programming language | Support IEC61131-3 (LD/ST/CFC/SFC) | | |
| | Program download | Support binary object code and user engineering (active, passive) downloads | | |
| | Program upload | Support | | |
| | Program encryption | Support user engineering, POU, and target file encryption | | |
| | Controller encryption | Support locking/unlocking the controller | | |
| | Power-off maintenance | Support | | |
| | Automatically add libraries | Support | | |
| Online system upgrade | Support | | | |
| Desktop operating system | Ubuntu/Win10 | Ubuntu | Ubuntu | |
| Real time clock (hold time) | Yes (15 days), accuracy ± 60 seconds/month | | | |
| Module power | Working voltage (VDC) | 20.4~28.8(-15%~+20%) | | |
| | Rated voltage (VDC) | 24 | | |
| | Power consumption (W) | 80 | 45 | 30 |
| | Anti-reverse connection | Not support | | |
| environment | Working temperature (°C) | -40~+60 | -10~+60 | |
| | Storage temperature (°C) | -40~+80 | -20~+80 | |
| | Humidity | 5~95%, no condensation | | |
| Authentication | CE, FCC, CB, EAC, UKCA | | | |

1.4. Ordering Information of Product

| Product series | Order model | Description |
|----------------|-------------|--|
| SX58xx | SX5820-0001 | 2*Ethernet port, 2*USB, 1*RS232/RS485/RS422(software configuration), 1*CAN, 1*HDMI, ECAT axis: 32, USB 3.0 camera: 1, GigE interface camera: 1, memory 4G |
| SX51xx series | SX5132-1010 | 4*Ethernet port, 2*USB, 1*RS232/RS485/RS422 (software configuration), 1*CAN, 1*HDMI, up to 4 direct axis extensions, ECAT axis: 32, USB3.0 camera: 2, GigE interface camera: 2, memory 4G |
| | SX5132-2010 | 4*Ethernet port, 2*USB, 1*RS232/RS485/RS422 (software configuration), 1*CAN, 1*HDMI, ECAT axis: 32, USB 3.0 camera: 2, GigE interface camera: 2, memory 8G |
| | SX5164-1010 | 4*Ethernet port, 2*USB, 1*RS232/RS485/RS422 (software configuration), 1*CAN, 1*HDMI, up to 8 direct axis extensions, ECAT axis: 64, USB3.0 camera: 2, GigE interface camera: 2, memory 4G |
| | SX5100-1010 | 4*Ethernet port, 2*USB, 1*RS232/RS485/RS422 (software configuration), 1*CAN, 1*HDMI, up to 16 direct axis extensions, ECAT axis: 128, USB3.0 camera: 2, GigE interface camera: 2, memory 4G |
| | SX5100-2010 | 4*Ethernet port, 2*USB, 1*RS232/RS485/RS422 (software configuration), 1*CAN, 1*HDMI, ECAT axis: 128, USB3.0 camera: 2, GigE interface camera count: 2, memory 8G |
| SX21xx series | SX2133 | 4*Ethernet port, 4*USB, 1*RS232/RS485/RS422 (software configuration), 1*CAN, 1*HDMI, ECAT axis: 256, USB 3.0 camera: 4, GigE interface camera: 6 or more, default memory16G, storage disk 256G |

2.SX51xx series

2.1.Product Overview

SX51xx series is a new generation of Embedded PC integrating computing and control independently developed by SINSEGYE relying on its rich experience in industrial control and computer.

SX51xx series Embedded PC adopts fanless and low-power design, equipped with Intel Atom® processor, and can support up to 4*Gigabit Ethernet, 1*HDMI, 2*USB3.0, 1*serial port (R232/RS422/RS485 optional) and 1*CAN. Besides, SX51xx series of industrial intelligent computers shave favorable scalability, supporting the expansion of ordinary IO and process modules, which can realize applications with large demand for I/O scale and complex processes.



2.2.Panel Description

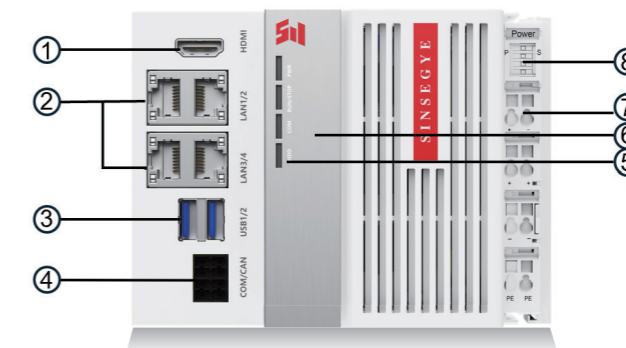

| No. | Name | Description |
|-----|--------------------------|---|
| 1 | HDMI | Display interface supports 1080P, max 4k |
| 2 | LAN1~4 | LAN port, support 100/1000MBASE-T (X) interface |
| 3 | USB1/2 | 2*USB 3.0 interfaces |
| 4 | COM/CAN | Support RS232/RS485/RS422, optional |
| 5 | Running status indicator | PWR: Power indicator RUN/STOP: Running indicator COM: Communication indicator HDD: Hard disk indicator |
| 6 | CFast card slot | |
| 7 | Power interface | Support 24V (-15% ~ +20%) DC power supply, recommended 24V DC input for rated voltage |
| 8 | Power indicator | |

2.3. Definition of Indicators

| Indicator type | Color | Status | Meaning |
|--------------------------------|----------------------|--------------------------------------|--|
| Power supply PWR | Green | On | The power supply is normal |
| | | Off | The power supply is abnormal or there is no corresponding power loading. |
| Running indicator RUN/STOP | Green/Yellow /Red | Green On | The main controller is in RUN state, and the user program is running. |
| | | Green Flash (1Hz) | The user program area is empty or the user project is invalid |
| | | Yellow On | The main controller is in STOP state, and the user program has stopped |
| | | Yellow Flash (1Hz) | The main controller is undergoing RTE upgrade. |
| | | Red Flash | Some or more diagnosable faults of controller (flashing at 1Hz N times, OFF for 30s, cycle.) |
| Communication indicator COM | Green/Yellow | Green Flash (1Hz) | Serial communication is sending and receiving data |
| | | Green Off | Serial communication is not sending or receiving data |
| | | Yellow Flash (1Hz) | Any network port is sending and receiving data |
| | | Yellow OFF | No data transmission or reception on the network port |
| | | Green/Yellow Flash alternately (1Hz) | Both serial and network ports are sending or receiving data. |
| Hard disk indicator HDD | Blue | Flash(1Hz) | Be able to access HDD hard drive or the hard drive is performing read and write operations. |
| | | Off | Unable to access or no access to HDD hard drive. |

2.4. Structural Dimension Diagram

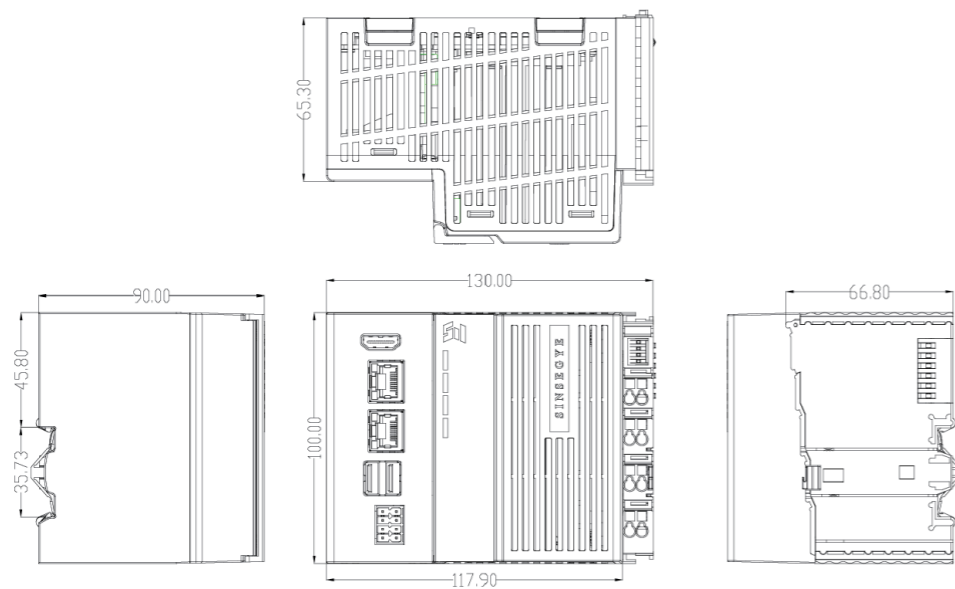

3. SX21xx Series

3.1. Product Overview

SX21xx series is a high-end Embedded PC with integrated computing and control, independently developed by SINSEGYE. SX21xx series have abundant I/O interface resources, supporting 4*Gigabit Ethernet, 1*HDMI, 4*USB3.0, 1*serial port (RS232/RS422/RS485 optional), and 1*CAN. Besides, SX21xx series have favorable scalability, supporting expansion modules such as Gigabit Ethernet ports, AI inference cards, serial ports, wireless and I/O, to meet complex on-site application scenarios.



3.2. Panel Description



| No. | Name | Description |
|-----|--------------------------|---|
| 1 | HDMI | Display interface supports 1080P, max 2k |
| 2 | LAN1~4 | LAN port, supporting 100/1000MBASE-T (X) interface |
| 3 | USB1-4 | 4*USB 3.0 interfaces |
| 4 | COM/CAN | Support RS232/RS485/RS422 optional |
| 5 | CFast card slot | |
| 6 | Running status indicator | PWR: Power indicator; RUN/STOP: Running indicator; COM: Communication indicator; HDD: Hard disk indicator Refer to the indicator instructions for details |
| 7 | Power indicator | |
| 8 | Power interface | Support 24V (-15% ~ +20%) DC power supply |

3.3. Definition of indicators

| Indicator type | Color | Status | Meaning |
|-----------------------------------|----------------------|-----------------------------------|---|
| Power supply PWR | Green | On | The power supply is normal |
| | | Off | The power supply is abnormal or there is no corresponding power loading. |
| Running indicator RUN/STOP | Green/Yellow /Red | Green On | The main controller is in RUN state, and the user program is running. |
| | | Green Flash | The user program area is empty or the user project is invalid |
| | | Yellow On | The main controller is in STOP state, and the user program has stopped |
| | | Yellow Flash | The main controller is undergoing RTE upgrade. |
| Communication indicator COM | Green/Yellow | Green Flash | Serial communication is sending and receiving data |
| | | Green OFF | Serial communication is not sending or receiving data |
| | | Yellow Flash | Any network port is sending and receiving data |
| | | Yellow OFF | No data transmission or reception on the network port |
| Hard disk indicator HDD | Blue | Green/Yellow Flash alternately | Both serial and network ports are sending or receiving data. |
| | | Flash | Be able to access HDD hard drive or the hard drive is performing read and write operations. |
| | | OFF | Unable to access or no access to HDD hard drive. |

3.4. Structural Dimension Diagram

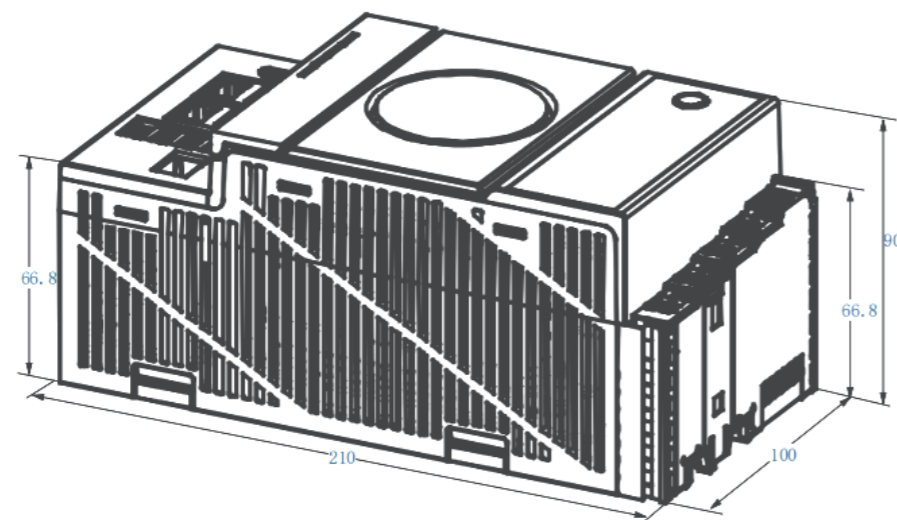

4. SX58xx Series

4.1. Product Overview



SX58xx is an ultra-compact Embedded PC integrating computing and control, independently developed by SINSEGYE relying on its rich experience in industrial control and computer.

SX58xx is equipped with low power Intel Celeron® processor. It supports 2*Giga-bit Ethernet interfaces, 2*USB3.0, 1*HDMI, 1*serial port (RS232/RS422/RS485 optional), and 1*CAN. Meanwhile, it supports remote IO modules and high/low speed local expansion module (self-adaptive). In addition, SX58xx adopts a modular design with a size of only 80 * 100 * 90mm, which is suitable for applications with strict requirements for installation space.

4.2. Panel Description

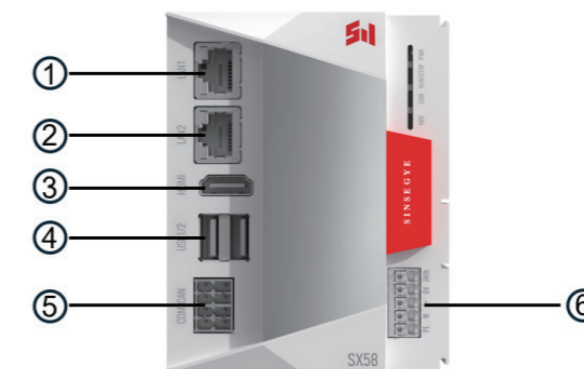

| No. | Name | Description |
|-----|-----------------|---|
| 1 | LAN1 | 100/1000MBASE-T (X) interface |
| 2 | LAN2 | 100/1000MBASE-T (X) interface |
| 3 | HDMI | Display interface support 1080P, max 4k |
| 4 | USB1/2 | 2*USB 3.0 interfaces |
| 5 | COM/CAN | RS232/RS485/RS422 optional |
| 6 | Power interface | 24V (-15%~+20%) DC power supply, recommended 24V DC input for rated voltage |

4.3. Definition of Indicators

| Indicator type | Color | Status | Meaning |
|--------------------------------|-----------|------------------|---|
| Power supply PWR | Green | On | The power supply is normal |
| | | Off | The power supply is abnormal or there is no corresponding power loading. |
| Running indicator RUN/STOP | White/Red | White Flash(1Hz) | The main controller is in RUN state, and the user program is normal. |
| | | Red On | The main controller is in STOP state, and the user program is stopped. |
| | | Red Flash(1Hz) | Some or more diagnosable faults of controller (flashing at 1Hz N times, OFF for 30s, cycle) |
| Communication indicator COM | White | Flash(1Hz) | Serial communication is sending and receiving data |
| | | OFF | Serial communication is not sending or receiving data |
| Hard disk indicator HDD | White | Flash(1Hz) | Be able to access HDD hard drive or the hard drive is performing read and write operations. |
| | | OFF | Unable to access or no access to HDD hard drive. |

4.4. Structural Dimension Diagram

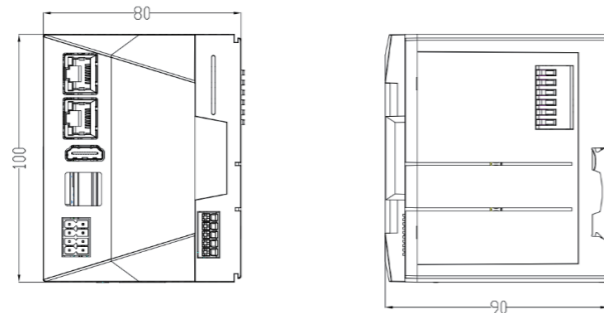

4.5. Expansion Module Description

4.5.1. Local IO modules

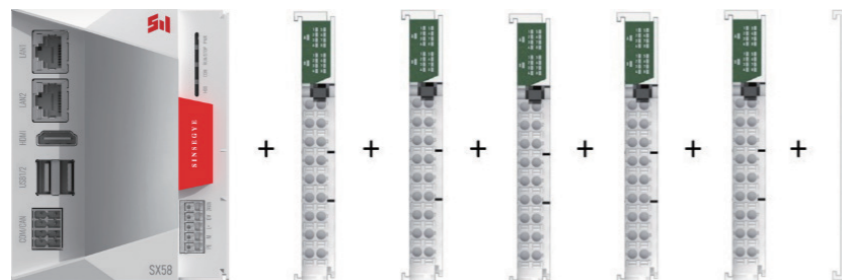

| Local IO modules | Module | Extension Interface Description | Remarks |
|------------------|--------|---------------------------------|---|
| SRE | SRExxx | Support EtherCAT protocol | SX58xx can automatically recognize the type of module |
| SRR | SRRxxx | Support RS485 protocol | |

5.5. Installation of Embedded Industrial Intelligent Computer

5.1. Precautions before Installation

- Do not tighten the equipment with excessive torque to avoid damaging the terminals and the equipment.
- Before installation, please ensure that the product is powered off.

5.2. Requirements for Installation Environment

It is not recommended to install embedded industrial intelligent computers in the following environments:

- Places with environmental humidity out of the range of 10%RH ~ 95%RH ;
- Places with corrosive or flammable gases;
- Places with high levels of conductive powders such as dust and iron powder, oil mist, salt, and organic solvents;
- Places where strong electric and magnetic fields occur;
- Places that can cause direct vibration and conductive impact to the equipment.

5.3. Installation Method

Please follow the steps below to fix and install the controllers:

- Select the installation location of the device (such as vertical to wall or cabinet wall). Ensure sufficient installation space and good heat dissipation.
- Tilt the device body and pull down the movable component of the caliper seat downwards.
- Rotate the equipment body to insert the caliper seat into the caliper. After the equipment body is locked, release the active component.

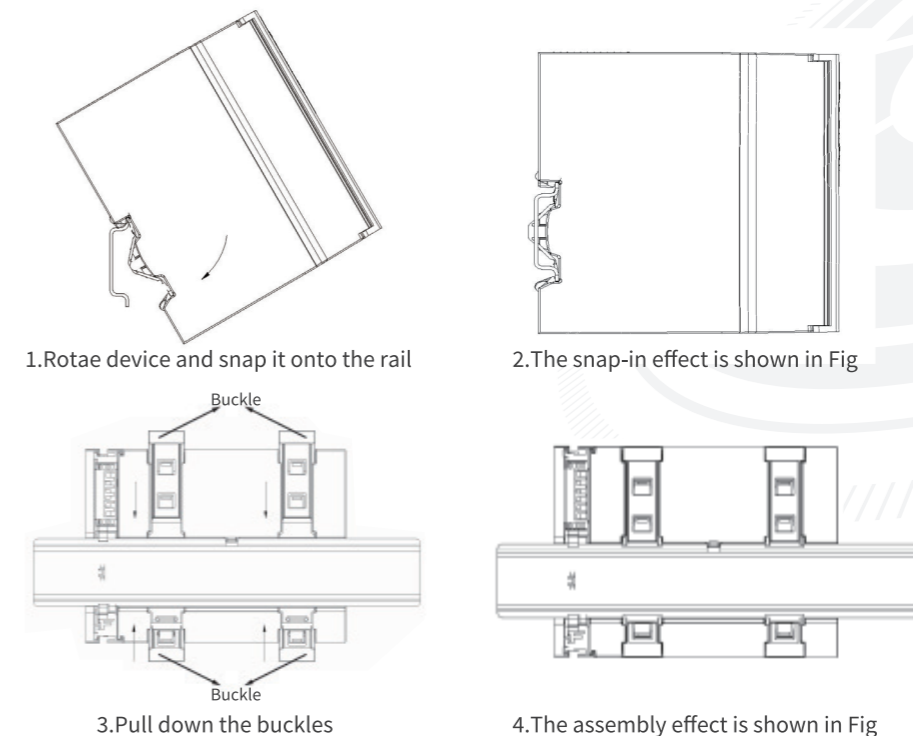

6. Electrical Installation

6.1. On-site Wiring Requirements

6.1.1. Grounding Requirements

There is a grounding point designed at the DIN rail of controller. After the device is installed on DIN rail, the rail needs to be well grounded. Choose thick and short grounding wire.

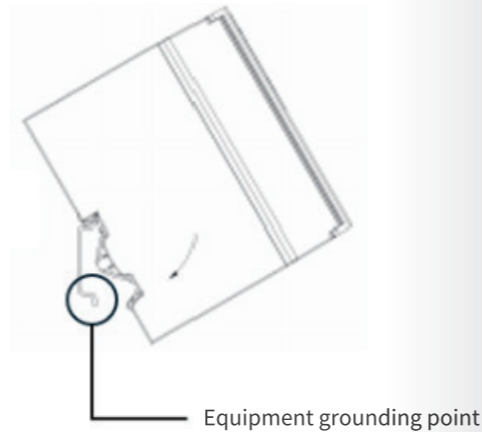

6.1.2. Recommended Wiring Requirements

Cable requirements

| Classification | Typical cable | Cable requirements |
|-------------------------|-------------------------------------|--|
| High speed signal cable | Ethernet | Shielded Class 5 or above |
| Low speed signal cable | Serial port signal and low-speed IO | Standard cable |
| Power cable | DC power cord DC24V | To be selected according to the power, please refer to the figure for reference. |
| Display cable | HDMI display cable | Shielded cable |

Other precautions:

- The relationship between wire cross-sectional area and current carrying capacity, please select the power cable correctly based on the equipment power.
- When the length of parallel cable route increases, the spacing should be appropriately increased.
- The electromagnetic environment is relatively harsh in the area close to power cables or on-site, magnetic rings or other methods can be used to reduce interference.
- To reduce cross interference, the spacing should be appropriately increased when the length of parallel cable routing increases.
- In addition to maintaining spacing, shielding plates can also be installed between different types of cables.

6.2. Power Wiring Instructions

The power terminal module requires an external voltage source to provide 24V DC (-15%~+20%) power. The power cable is connected to the power terminal module through a spring-loaded terminal module. The recommended cable cross-section shall not below 0.5mm².

6.3. Interface Wiring Instructions

6.3.1. Network Port Description

Ethernet communication specifications

SX series industrial intelligent computers have 2/4 Gigabit Ethernet ports, as defined in the following table:

| No. | Network port | Function |
|-----|--------------|--|
| 1 | LAN 1 | Programming port (for downloading and monitoring, etc.), Modbus TCP, EtherNet/IP, Profinet, OPC UA, Freepoint communication Factory default fixed IP address: 192.168.1.200 |
| 2 | LAN 2/3/4 | EtherCAT master network port, Modbus TCP, EtherNet/IP, Profinet, OPC UA, Freepoint communication |

Note: The IP addresses of LAN1 and LAN2/3/4 ports cannot be in the same network segment.

RJ45 Ethernet cable connection

The 100/1000Base-T (X) Ethernet interface adopts standard RJ45 connector with adaptive function, which can automatically configure to 100M/1000M state and full duplex/half duplex operation mode. It also supports MDI/MDI-X self-identification function of cables, which can be connected to terminal devices and network devices with direct or cross network cables.

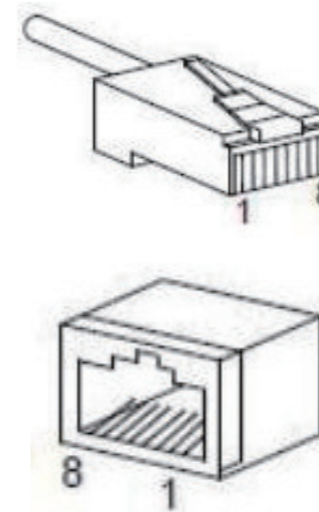

| Pin No. | MDI-X | MDI |
|---------|----------------------------|------------------------------|
| 1 | Send/receive data (TRD+) | Send/receive data (TRD 0+) |
| 2 | Send/receive data (TRD 1-) | Send/receive data (TRD 0-) |
| 3 | Send/receive data (TRD 0+) | Send/receive data (TRD 1+) |
| 4 | Send/receive data (TRD 3+) | Send/receive data (TRD 0 2+) |
| 5 | Send/receive data (TRD 3-) | Send/receive data (TRD 0 2-) |
| 6 | Send/receive data (TRD 0-) | Send/receive data (TRD 0 1-) |
| 7 | Send/receive data (TRD 2+) | Send/receive data (TRD 0 3+) |
| 8 | Send/receive data (TRD 2-) | Send/receive data (TRD 0 3-) |

Note: "+" and "-" represent the polarity of the voltage level

Network port indicator

SX51xx/SX21xx Network port indicator

| Indicator | Color | Status | Function description |
|---|--------|-----------|---|
|  | Yellow | Off | Not connected |
| | | Flash | 100Mbps connected, with sending or receiving data |
| | | Remain On | Connected already |
| Green | Green | OFF | Not connected |
| | | Flash | Gigabit connected with sending or receiving data |
| | | Remain On | Gigabit connected |

SX58xx Network port indicator

| Indicator | Color | Status | Function description |
|---|---------------|-----------|---|
|  | Yellow | Off | Not connected |
| | | Flash | 100Mbps connected, with sending or receiving data |
| | | OFF | Not connected |
| Green /Orange | Green /Orange | Green On | 100Mbps connected |
| | | Orange On | Gigabit connected |

Requirements for Ethernet cables

| Ethernet cable specifications | Requirement |
|-------------------------------|------------------------------------|
| Network cable type | CAT5e /Elastic Cross |
| Meet the standards | EIA/TIA568A, EN50173, ISO/IEC11801 |
| Wire type | AGW26 |
| Number of line pairs | 4 |
| Cable length between devices | ≤100 meters |

6.3.2.USB description

The USB interface is located on the front panel of the device, which are all USB 3.0 interfaces and use standard A female socket interfaces. The definition of USB interface pins is shown in the following figure:

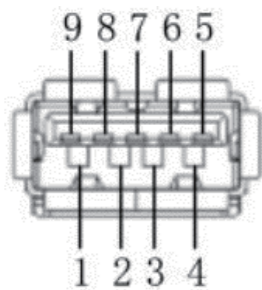

| Pin No. | Definition | Pin No. | Definition |
|---------|------------|---------|------------|
| 1 | VBUS | 2 | D- |
| 3 | D+ | 4 | GND |
| 5 | SSRX- | 6 | SSRX+ |
| 7 | GND | 8 | SSTX- |
| 9 | SSTX+ | 10 | Ground |
| 11 | Ground | | |

6.3.3 HDMI Description

HDMI interface is located on the front panel of the device and adopts the standard A female socket interface. The definition of HDMI interface pins is shown in the following figure:

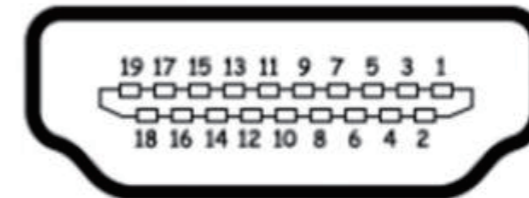

| Pin# | Signal | Pin# | Signal |
|------|--------------------|------|-------------------|
| 1 | TMDS data 2+ | 11 | TMDS clock shield |
| 2 | TMDS data 2 shield | 12 | TMDS clock- |
| 3 | TMDS data 2- | 13 | CEC |
| 4 | TMDS data 1+ | 14 | No connected |
| 5 | TMDS data 1 shield | 15 | DDC clock |
| 6 | TMDS data 1- | 16 | DDC data |
| 7 | TMDS data 0+ | 17 | Ground |
| 8 | TMDS data 0 shield | 18 | +5V power |
| 9 | TMDS data 0- | 19 | Hot plug detect |
| 10 | TMDS clock+ | | |

6.3.4.Serial /CAN Instructions

COM/CAN interface adopts 2 * 4P spring terminals and can be optionally configured with RS-232/RS-485/RS-422.

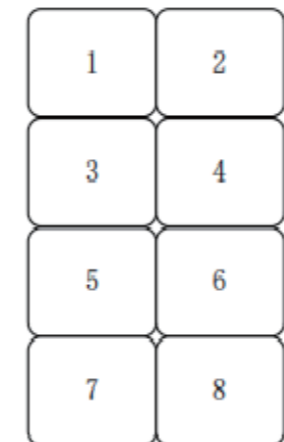

The pin definitions of SX21xx and SX51xx are shown in the following figure:

| Pin | RS-232/CAN | RS-422/CAN | RS-485/CAN |
|-----|------------|------------|------------|
| 1 | DCD | TX- | DATA- |
| 2 | COM_GND | COM_GND | COM_GND |
| 3 | RXD | TX+ | DATA+ |
| 4 | CAN_1_H | CAN_1_H | CAN_1_H |
| 5 | TXD | RX+ | |
| 6 | CAN_1_L | CAN_1_L | CAN_1_L |
| 7 | DTR | RX- | |
| 8 | CAN_GND | CAN_GND | CAN_GND |

The pin definition of SX58xx is shown in the following figure:

| Pin | RS-232/CAN | RS-422/CAN | RS-485/CAN |
|-----|------------|------------|------------|
| 1 | DCD | TX- | DATA- |
| 2 | COM_GND | COM_GND | COM_GND |
| 3 | RXD | TX+ | DATA+ |
| 4 | CAN_1_H | CAN_1_H | CAN_1_H |
| 5 | TXD | RX+ | |
| 6 | CAN_1_L | CAN_1_L | CAN_1_L |
| 7 | DTR | RX- | |
| 8 | CAN_GND | CAN_GND | CAN_GND |

Wiring precautions

- When expanding cable wiring, separate it from cables that transmit strong interference signals such as power lines (high voltage, high current).
- To avoid parallel wiring, it is recommended to use shielded twisted pair cables to improve anti-interference ability.
- Connect 120 Ω terminal matching resistors at both ends of the bus to prevent signal reflection, as shown in the figure.
- Connect to 32 nodes(Max), and the distance between each node branch line should be less than 3 meters.
- If using shielded cables, it is particularly important to note that the shielding layer must also be connected to the GND terminal. At any node or intermediate position, except for the GND terminal, the shielding layer must not be connected to any other place.

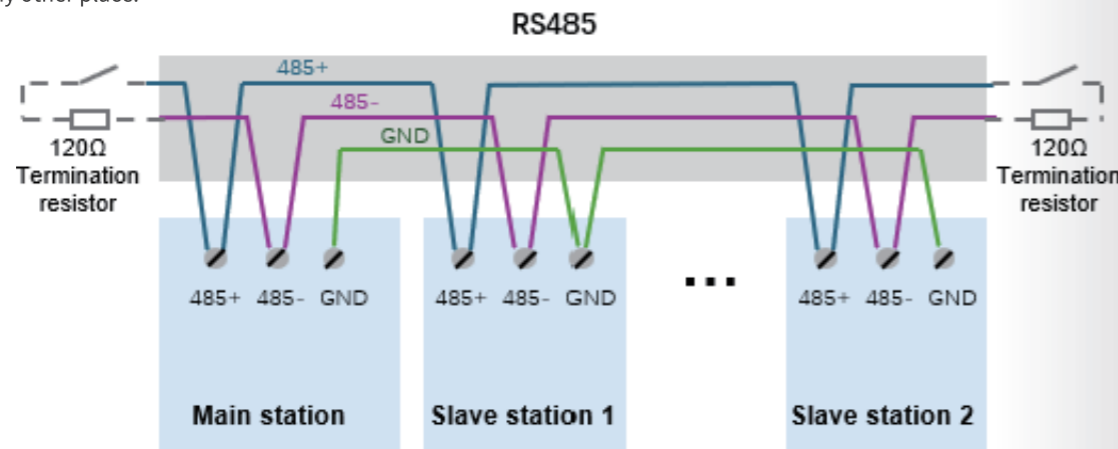

RS485 Communication Connection Diagram

7. Programming and Debugging

For the programming and debugging process, please refer to “MetaFature Basic Operations” .

8. Repairing and Maintenance

8.1. Notes

- Non-professionals are strictly prohibited from inspecting and maintaining the device or replacing components!
- It is prohibited to maintain the device when it is powered on to avoid the risk of electric shock!
- After cutting off the power supply of the device, not maintain the device at least after the time specified on the product warning label matures.
- Before maintenance, it is necessary to measure the voltage value between the positive and negative electrodes of the product battery and the voltage value between the positive and negative electrodes and the ground. Forbid maintaining the device unless the voltage is lower than 36V.
- During maintenance, protect the device and components from contacting or carrying flammable materials, and take anti-static measures.
- Avoid the cover plate falling off, otherwise it may cause harm to the product and personnel.
- Forbid to contaminate or damage the sealing ring, otherwise the sealing performance of the product will be negatively influenced, shorten its lifespan, and even pose a risk of explosion.

8.2. Items Subject to Regular Inspection

Components of industrial intelligent computers shall be inspected on a regular basis as they will age and be exposed to other issues due to environmental conditions over prolonged use. The inspection cycle is once every 6 to 12 months. The inspection interval can be appropriately shortened according to the actual usage situation.

| Item | Inspection Method | Judgment Criteria |
|-------------------------------|---|--|
| Power Supply | Use a multimeter to test and modify terminals and adjust the power supply within the allowable voltage variation range. | DC 24V (-15%~20%) |
| CPU resources | Regularly check CPU resources | Below 60% |
| Equipment surface temperature | Use a temperature gun to measure shell temperature | Below 70 °C |
| Fan | Open the protective cover and visually observe the operation of the fan | The fan is running, and the accumulated dust should be cleaned regularly |
| Status indicator | Visually observe indicator status and compare with description | No alarm |
| Ambient temperature | Measure the ambient temperature with thermometer | Refer to the environmental requirements corresponding to the device model |
| | Measure environmental humidity with hygrometer | Refer to the environmental requirements corresponding to the device model |
| | Is there any accumulation of dust, dirt, salt, or iron filings | Timely clean to avoid the spread of pollution sources |
| | Whether there are droplets of water, oil, chemicals, etc. | Timely clean to avoid the spread of pollution sources |
| Installation and wiring | Does it directly cause vibration or impact to the subject | It is necessary to isolate the vibration source in a timely manner to avoid the spread of pollution sources |
| | Is there any interference source nearby? | |
| Battery alarm | Is the screw for external wiring loose? | |
| | Is the external wiring cable about to break? | |
| Battery alarm | The controller does not have “low battery voltage” alarm message. | The service life has expired or is to be reached. The effective period at 25°C is generally 5 years, and the battery life varies depending on the model and ambient temperature. |

8.3.Maintainable Components

| Consumable name | Replaceable or not(Y/N) | Recommended replacement period |
|-----------------|-------------------------|--------------------------------|
| Cmos battery | Yes | 5 years at room temperature |
| CF card | Yes | Based on on-site requirements |
| Fan | Yes | 5 years |

8.3.1.Replace Battery/CF Card

Replace battery/CF card

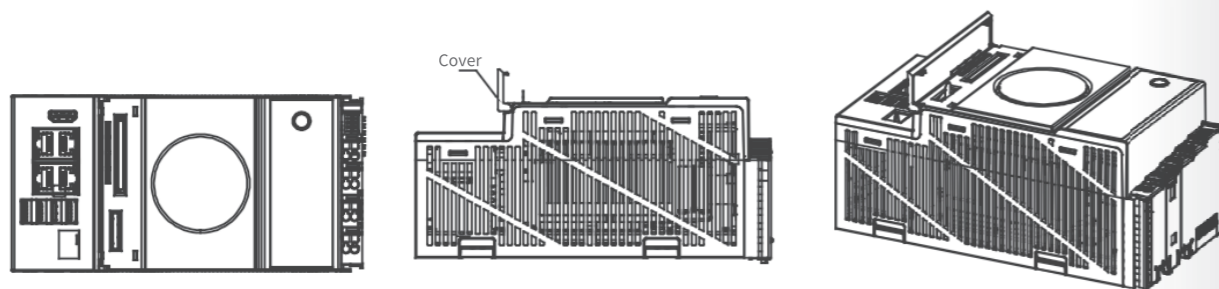

• Step 1: Opening the cover

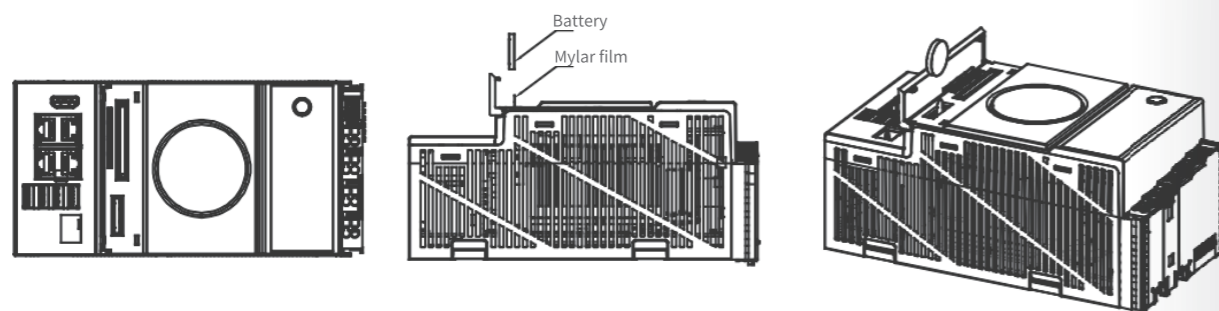

• Step 2: Take out the CMOS battery by pressing or using Mylar Film and replace it with a new battery. CF cards will eject by pressing. Replace it with a new one.

Notes

- When installing and disassembling batteries, it needs to be operated after the power is off.
- When installing battery, ensure that the positive and negative poles of the battery are correct.
- When replacing the battery and powering it on, please pay attention to whether the controller gives message on battery fault.
- After the power on, the system clock needs to be manually calibrated again to ensure the correct system time.

8.3.2.Replace Fan

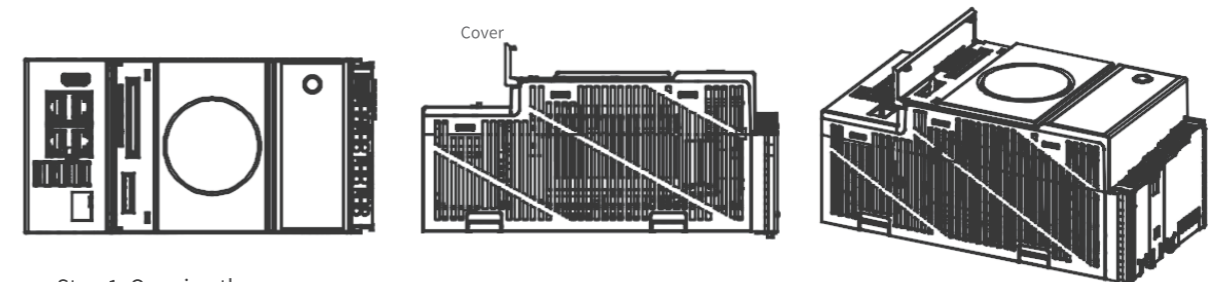

• Step 1: Opening the cover

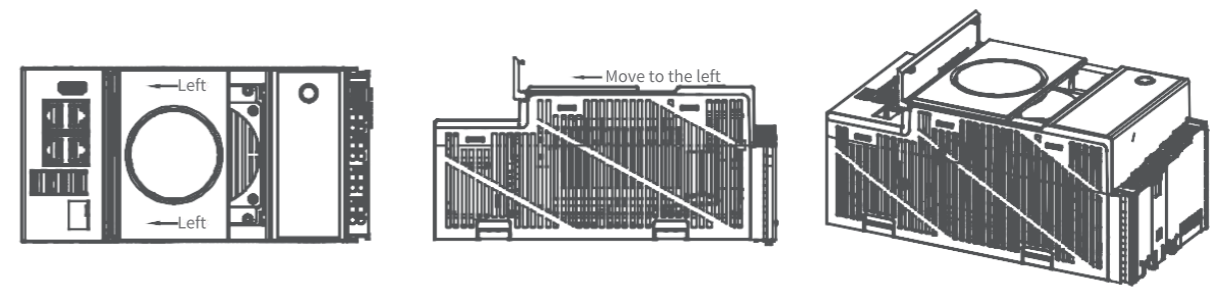

Step 2: gently press cover plate 2 and slide it to the left to remove the cover plate.

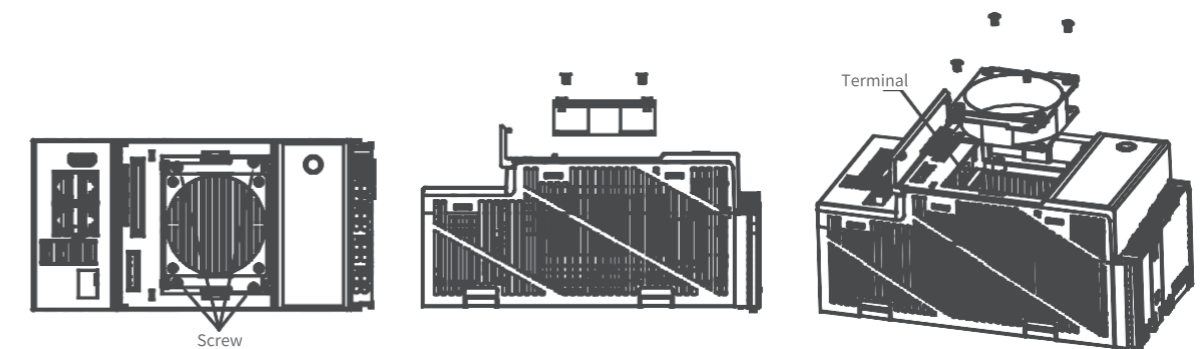

Step 3: With a screwdriver, unscrew the screws shown in the diagram and then remove the fan. Replace the fan with a new one.

8.4.Storage and Waste Recycling

Please contact a qualified electronic and electrical waste product disposal company to recycle and dispose of waste products in accordance with local regulations.