



Product introduction

Description



Standard horizontal installation



Vertical installation with cooling element

### Hygienic pressure transmitter

Hygienic pressure transmitter, designed for food and pharmaceutical industry, is suitable for CIP/SIP cleaning and sterilization. Smart compact design, the welded process diaphragm medium parts is made of high quality stainless steel 316L, roughness $\leq 0.4\mu\text{m}$ , filling fluid with hygiene standard in line with FDA certification, variety of international standard process connections are available.

Main parameters

Pressure types	Gauge pressure
Measuring range	10kPa-40MPa, please refer to the ordering information chapter
Output signal	4-20mA, 4-20mA+HART, customer
Reference accuracy	$\pm 0.2\%$ URL, $\pm 0.5\%$ URL, customer

Measuring medium

viscous, paste-like, adhesive, crystallising, particulatescontaining and contaminated media

Field of application

Pressure, level

Approvals



Technical specifications

Nominal value	Smallest calibratable span	Lower range limit (LRL)	Upper range limit (URL)	Overpressure limit*
40kPa	10kPa	-40kPa	40kPa	1MPa
250kPa	25kPa	-100kPa	250kPa	4MPa
1MPa	100kPa	-100kPa	1MPa	6MPa
3MPa	300kPa	-100kPa	3MPa	15MPa
10MPa	1MPa	-100kPa	10MPa	20MPa
40MPa	5MPa	-100kPa	40MPa	80MPa

The unit of the measuring range above can be converted into kg/cm<sup>2</sup>, MPa and kPa. Provide other measuring range according to requirements. Adjust requirements: lower range value (LRV) and upper range value (URV) can be adjusted within the scope of the upper and lower range limit, minimum measuring range ≤ |URV - LRV| ≤ maximum measuring range.

\*Limit value of overpressure: depends on the pressure value of the parts with lowest pressure capacity

Standard specifications and reference conditions

Test standard: GB/T28474 / IEC60770; zero based-calibration span, linear output, silicon oil filling, 316L stainless steel isolated diaphragm.

Performance specifications

The overall performance including but not limited to **【Reference accuracy】**, **【Environment temperature effects】**, **【Static pressure effects】** and other comprehensive error

Typical accuracy: ±0.2% URL

Stability: ±0.2% URL/year

Reference accuracy

Including linearity, hysteresis and repeatability. calibration temperature: 20°C±5°C

Linear output accuracy	Typical	±0.2% URL	Nominal value: 40kPa, 250kPa, 1MPa, 3MPa, 10MPa, 40MPa
	Max value	±0.5% URL	

The accuracy of square root output is 1.5 times of above linear reference output accuracy.

Ambient temperature effects

Within the range -20-80°C total impact ±0.2% URL/10K

Power supply effects

Zero and span change should not be more than ± 0.005% URL/V when power supply changes in 10.5/16.5-55VDC

Loading effects

Zero and span change should not be more than ± 0.05% URL/kΩ

Vibration effects

Vibration resistance	According to IEC60068-2-6 , 10g RMS (25-2000HZ)
Impact resistance	According to IEC60068-2-27 , 500g/1ms

Output signal

Signal	Type	Output
4-20mA	Linearity	Two wire
4-20mA+HART	Linearity	Two wire

Insulation resistance

≥ 20M Ω@ reference, 100VDC

Technical specifications

Damping time

Total damping time constant: equal to the sum of damping time of amplifier and sensor capsule
Damping time of amplifier: 0-100S adjustable
Damping time of sensor capsule (isolated diaphragm and silicon filling oil) $\leq 0.2S$
Startup after power off: $\leq 6S$
Normal services after data recovery: $\leq 31S$

Weight

Net weight: about 0.8kg ( without mounting bracket and process connection adaptor )
---

Environment condition

Items	Operational condition
Working temperature	-40-85°C, integrated LCD display: -20-70°C
Storage temperature	-40-110°C, integrated LCD display: -40-85°C
Media temperature	Hygienic fluid filling: -10-125°C; with heat exchange connector: -10-250°C* Silicon oil filling: -40-120°C, with heat exchange connector: -40-300°C*
Working humidity	0-95%RH
Protection class	IP67
Dangerous condition	ExiallCT4(GYB16.1965X)**
*Using heat exchange connector may lead to zero offset and temperature drift. The degree depends on mounting position and filling fluid	
**Please consult engineers for details	

Power supply

Item	Operating conditions
Standard	10.5-55VDC
HART protocol	16.5-55VDC, communication load resistance 250Ω
Load resistance	0-2119Ω for operation, 250-600Ω for HART protocol
Transmission distance	<1000 meters
Power consumption	$\leq 500mW@24VDC$ , 20.8mA

Power supply and load requirements

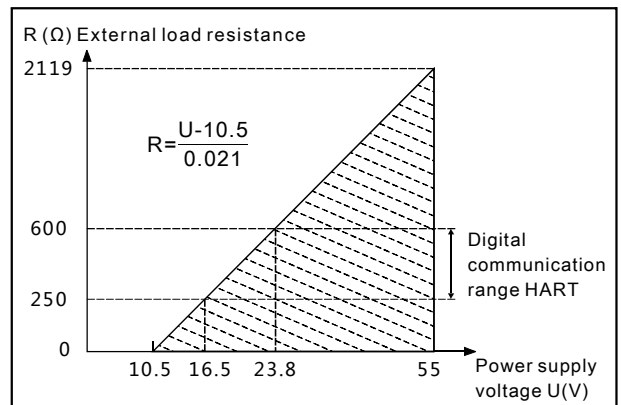

Technical specifications

EMC environment

NO.	Test items	Basic standards	Test conditions	Performance level
1	Radiated interference	GB/T 9254/CISPR22	30MHz-1000MHz	OK
2	Conducted interference (DC power port)	GB/T 9254/CISPR22	0.15MHz-30MHz	OK
3	Electrostatic discharge immunity test (ESD)	GB/T 17626.2/IEC61000-4-2	4kV(Contact ),8kV(Air)	B(Note2)
4	Immunity to radio frequency EM-fields	GB/T 17626.3/IEC61000-4-3	10V/m(80MHz-1GHz)	A(Note1)
5	Power frequency magnetic field Immunity test	GB/T 17626.8/IEC61000-4-8	30A/m	A(Note1)
6	Electrical fast transient / Burst Immunity Test	GB/T 17626.4/IEC61000-4-4	2kV(5/50ns,100kHz)	B(Note2)
7	Surge immunity requirements	GB/T 17626.5/IEC61000-4-5	1kV(Line to line) 2kV(Line to ground) (1.2us/50us)	B(Note2)
8	Immunity to conducted disturbances induced by radio frequency fields	GB/T 17626.6/IEC61000-4-6	3V(150kHz-80MHz)	A(Note1)

(Note 1)Performance level A: The performance within the limits of normal technical specifications.

(Note 2)Performance level B: Temporary reduction or loss of functionality or performance, it can restore itself. The actual operating conditions, storage and data will not be changed.

Menu function

Transmission module type

Output signal	Local control	Remote control
4-20mA+HART	LCD/3 buttons on body	HART
4-20mA	LCD/3 buttons on body	-

LCD display unit

Display mode	Details
PV	Process variable shows on main screen, percentage and progress bar shows on secondary screen
mA	Current shows on main screen, percentage and progress bar shows on secondary screen
%	Percentage shows on main screen, percentage and progress bar shows on secondary screen

Unit

Unit	Definition
kPa	Kilopascal
MPa	Megapascals
bar	Bar
psi	Pounds per square inch
mmHg	Millimetre(s) of mercury@0°C
mmH2O	Millimeter of water@4°C
mH2O	Meter of water@4°C
inH2O	Inches of water@4°C
ftH2O	Feet of water@4°C
inHg	Inches of mercury@0°C
mHg	Meter mercury column@0°C
TORR	Torr
mbar	Millibar
g/cm2	Gram per square centimeter
kg/cm2	Kilogram per square centimeter
Pa	PA
ATM	Standard atmospheric pressure
mm	Millimeter(Note1)
m	Meter(Note1)

Note1: length unit need mark medium density

Measuring menu set

Mark	State
URV	Upper range value, 20mA
LRV	Lower range value, 4mA

Damping time

Units	Setting range
S	0-100

Analog output type

Parameters	Output type
mA LINER	Linearity
mA $\sqrt{\quad}$	Square root

Alarm signal

Parameters	Alarm signal
ALARM NO	None
ALARM H	20.8mA
ALARM L	3.8mA

Fix output

Parameters	Fix output value
FIX/C NO	None
3.8000	3.8000mA
4.0000	4.0000mA
8.0000	8.0000mA
12.000	12.000mA
16.000	16.000mA
20.000	20.000mA
20.800	20.800mA

Quick menu

Parameter	Instruction
PV=0	Set current output to zero value, used to correct the error caused by static pressure and installation.
Zero adjustment	4mA re-range with pressure
Span adjustment	20mA re-range with pressure
Restore factory setting	Restore backup data when error

Product selection instruction

Sensor select instruction

Code	Nominal value	Description
S403G	40kPa	Range -40kPa-40kPa, smallest calibratable span 10kPa
S254G	250kPa	Range -100kPa-250kPa, smallest calibratable span 25kPa
S105G	1MPa	Range -100kPa-1000kPa, smallest calibratable span 100kPa
S305G	3MPa	Range -0.1MPa-3MPa, smallest calibratable span 300kPa
S106G	10MPa	Range -0.1MPa-10MPa, smallest calibratable span 1MPa
S406G	40MPa	Range -0.1MPa-40MPa, smallest calibratable span 5MPa

Adjust requirements: lower range value (LRV) and upper range value (URV) can be adjusted within the scope of the upper and lower range limit, minimum measuring range  $\leq |URV - LRV| \leq$  maximum measuring range

Code	Position	Instruction
F	Sensor seal	Stainless steel welding seal

Electrical connection

Code	Item	Description
F1	Electrical connection	Stainless steel terminal, aviation plug M12*1 (4 pin) (H2), IP67, vertical mounting
F2		Stainless steel terminal, aviation plug M12*1 (4 pin) (H2), IP67, horizontal mounting

Housing(F1)

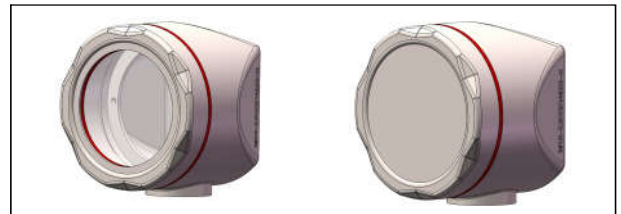

Housing(F2)



Aviation plug, M12\*1, 4 pin(H2)



Electrical connection

Aviation plug, M12\*1, 4 pin(H2)

label	Two wires
1	Power+
2	
3	
4	Power-

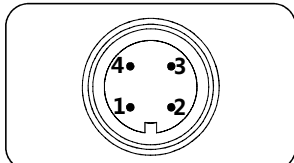

Product selection instruction

Electrical connection accessories

Aviation plug straighter(J1)

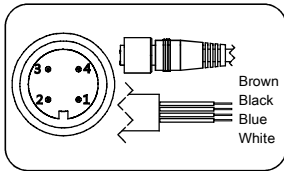

label	Two wires
1/Brown	Power+
2/White	
3/Blue	
4/Black	power-

Aviation plug elbow(J2)

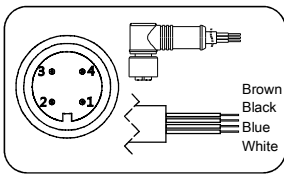

label	Two wires
1/Brown	power+
2/White	
3/Blue	
4/Black	Power-

Aviation plug straighter(J4)

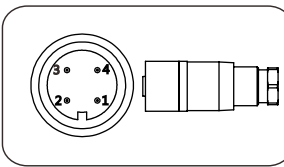

Label	Two wires
1	Power+
2	
3	
4	Power -

Aviation plug elbow(J5)

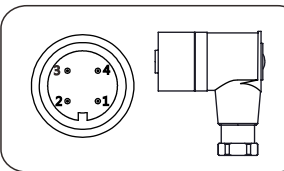

Label	Two wires
1	Power+
2	
3	
4	Power -

Transmission module

Code	Items	Description
F	Output signal	4-20mA two wire, power supply: 10.5-55VDC
H		4-20mA+HART two wire, power supply: 16.5-55VDC
A	Display	Without display
C		With LCD display

Display module(C)



Process connection select instruction

Code	Items	Description
4	Process connection material	Stainless steel, SUS304
6		Stainless steel, SUS316
NT	Connection type	Standard connection, medium temperature: -25-80°C
F	Isolated filling fluid	Hygienic fluid filling, Neobee M-20, process temperature: -10-180°C
S		Silicon oil filling, process temperature: -45-205°C
S	Isolated diaphragm material	Stainless steel, SUS316L
H		Hastelloy C
M01	Process connection specifications	M20*1.5(M), GB/T193-2003, ISO261
G01		G1/2(M), GB/T7307, ISO228, BS2779
G07		G1-1/2(M), GB/T7307, ISO228, BS2779
G12		G1(M), metal seal GB/T7307, ISO228, BS2779

Product drawing and dimension

Standard drawing and dimension with display(C)/ without display (A)vertical installation(F1)(unit:mm)

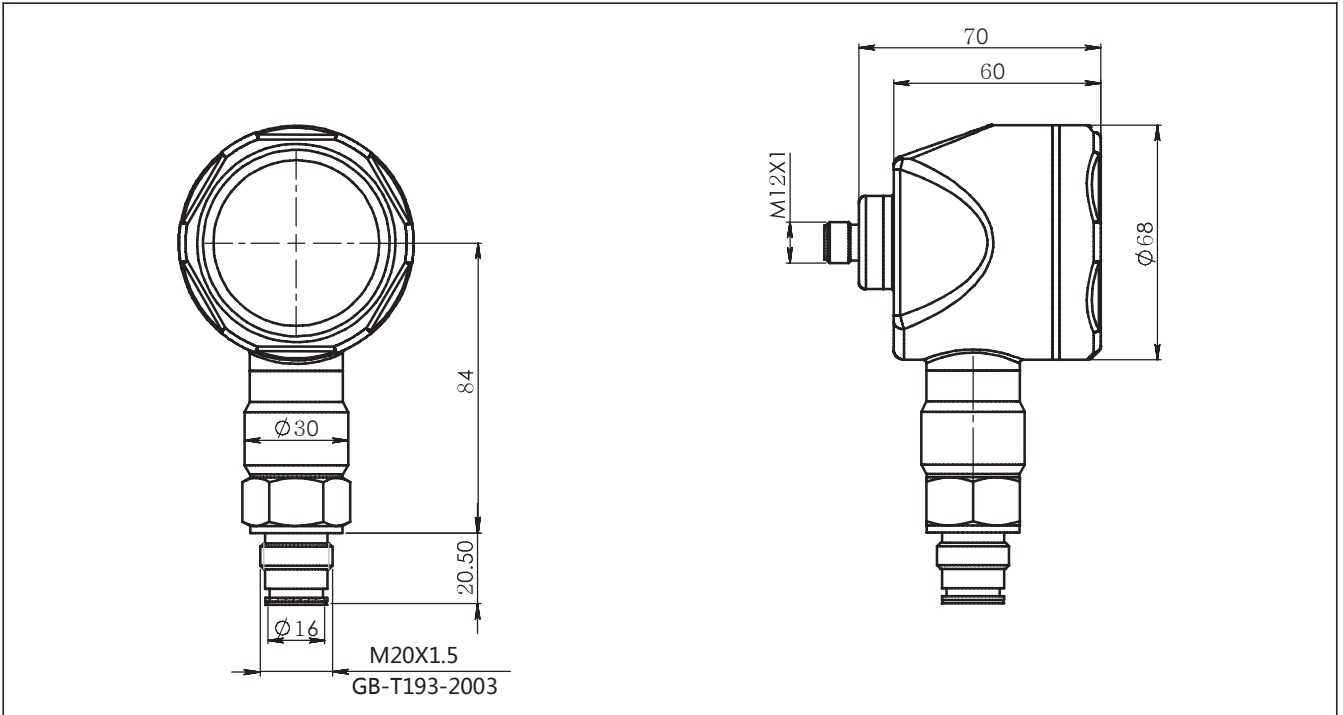

Standard drawing and dimension with display(C) / without display(A) horizontal installation(F2)(unit:mm)

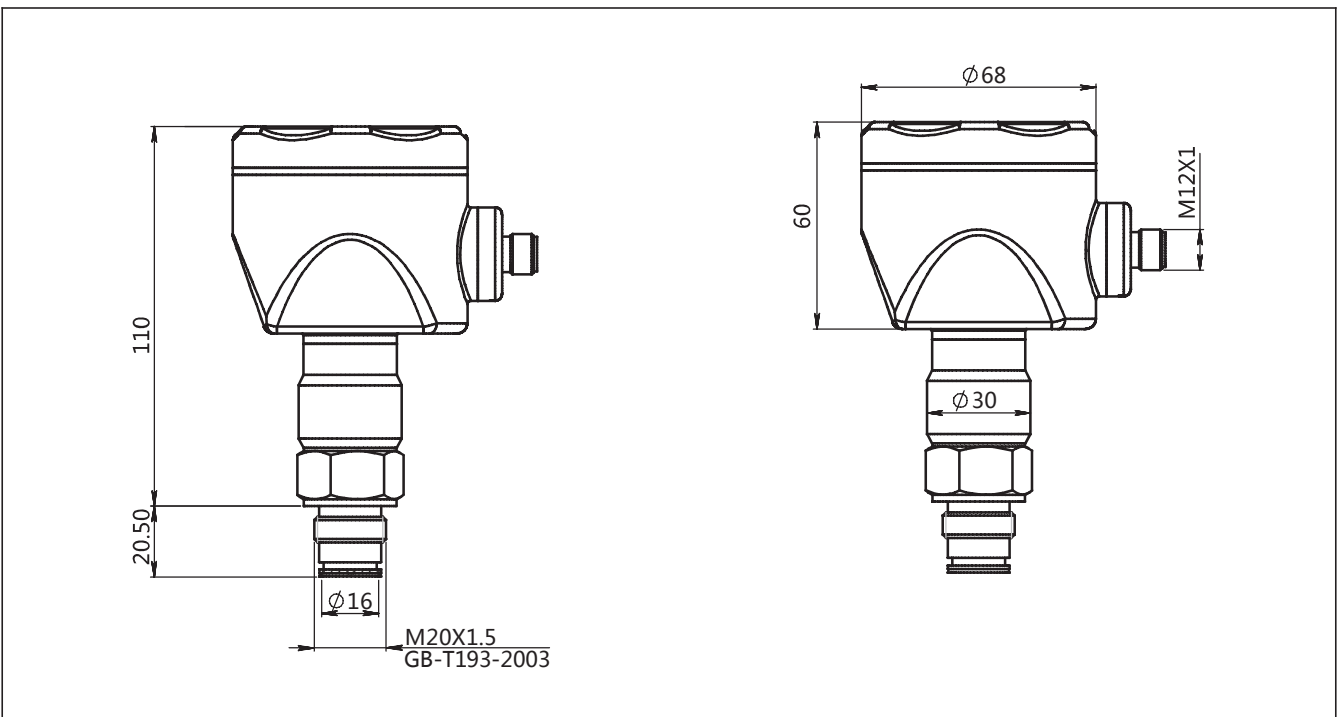

Disclaimer: all the data used in the product description is not legally binding. Relevant technical details may be changed due to further improve



Product drawing and dimension

Drawing and dimension with display(C)/ without display (A) vertical installation(F1) with cooling element (unit:mm)

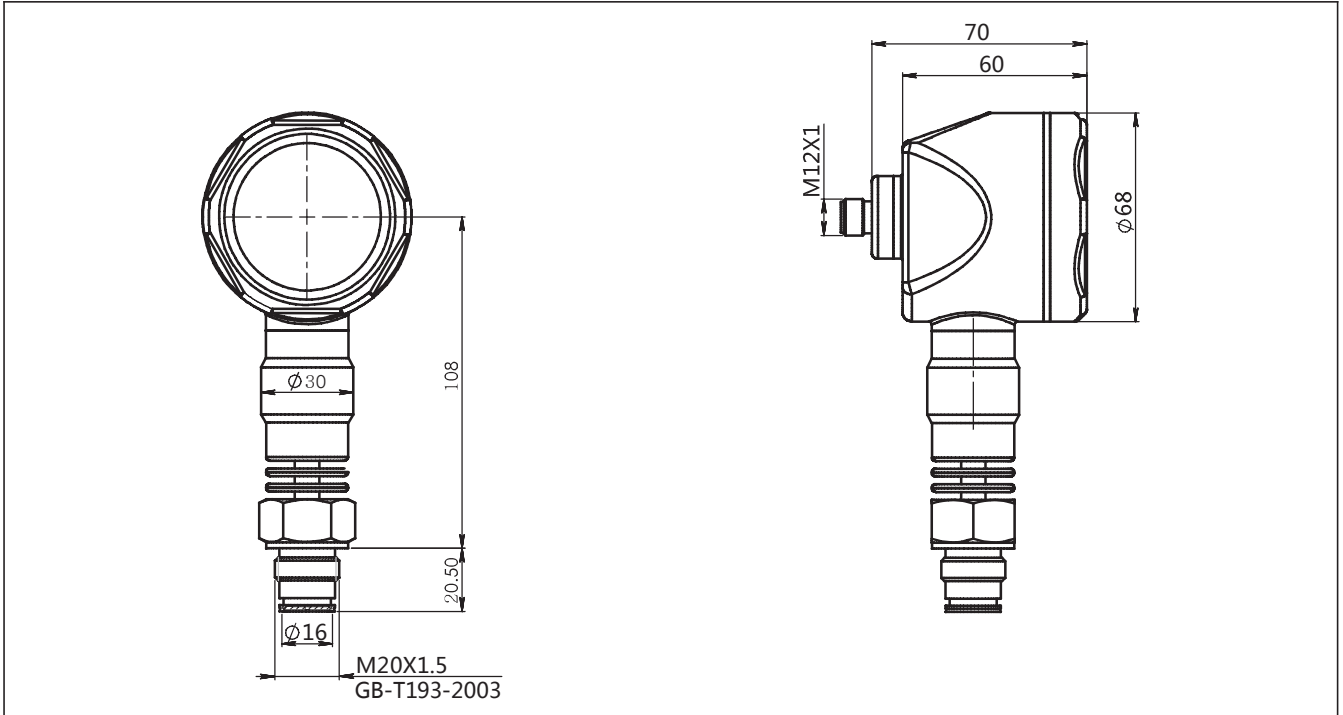

Drawing and dimension with display(C)/ without display (A) horizontal installation(F2) with cooling element (unit:mm)

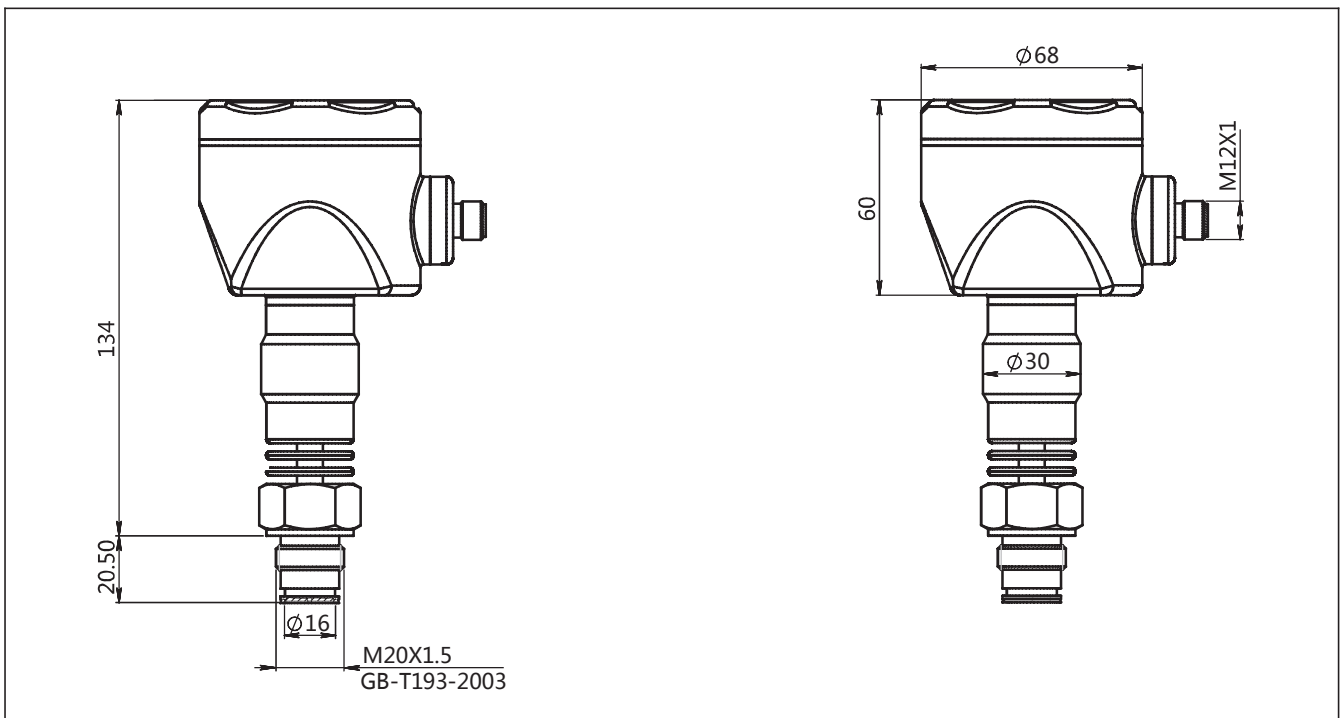

Disclaimer: all the data used in the product description is not legally binding. Relevant technical details may be changed due to further improve

Product drawing and dimension

Process connection(M01)(unit:mm)

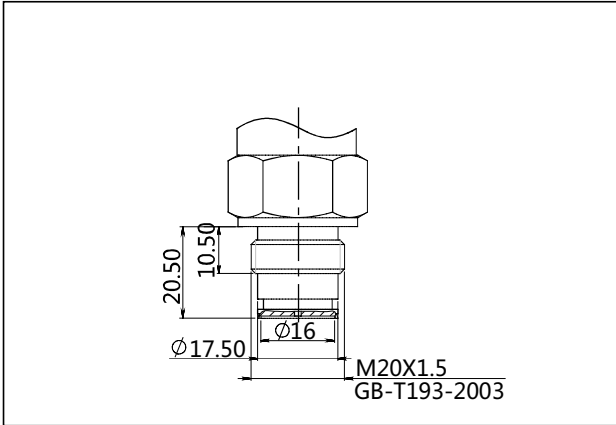

Process connection(G01)(unit:mm)

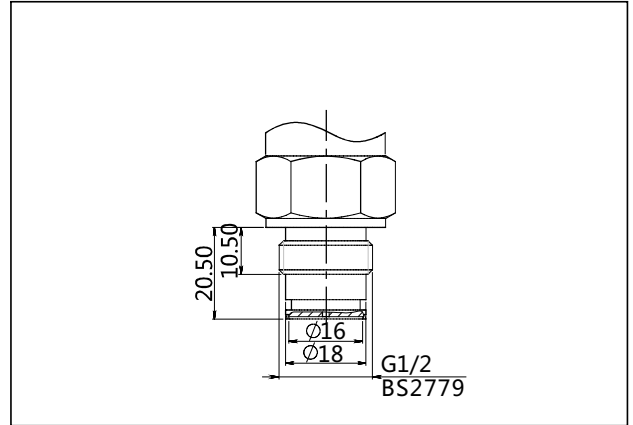

Process connection(G07)(unit:mm)

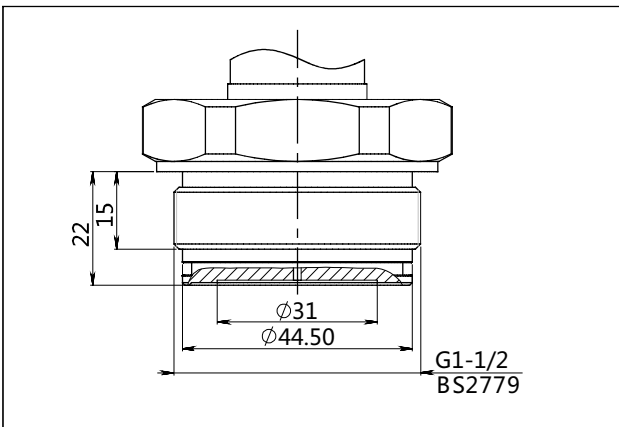

Process connection(G12)(unit:mm)

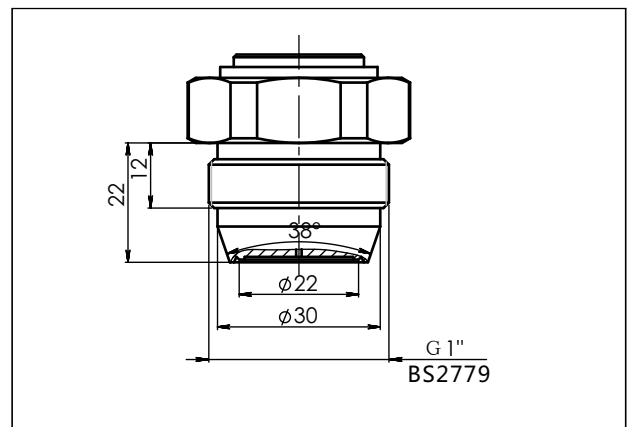

Welding adaptor(Z3)(unit:mm)

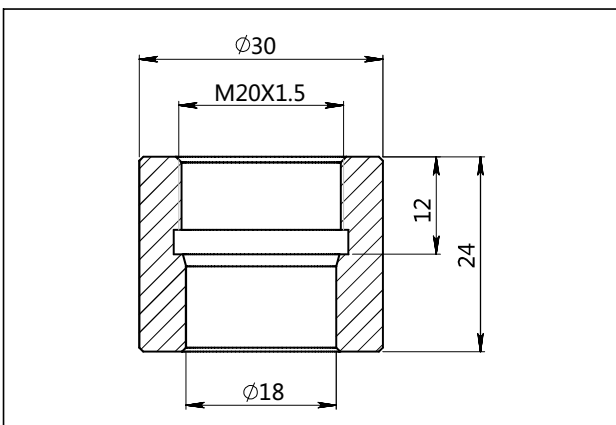

Welding adaptor(Z4)(unit:mm)

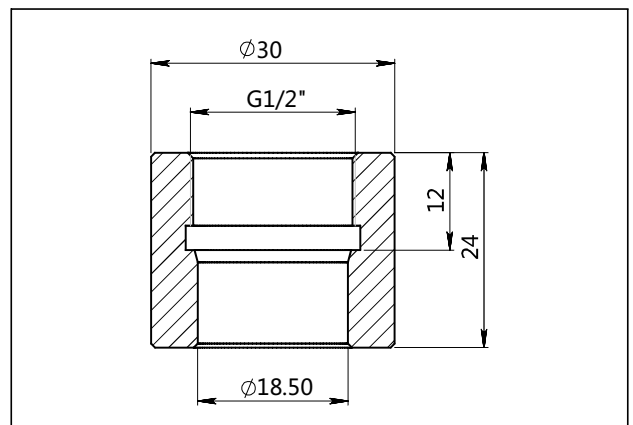

Disclaimer: all the data used in the product description is not legally binding. Relevant technical details may be changed due to further improve

Product drawing and dimension

Welding adaptor(Z5)(unit:mm)

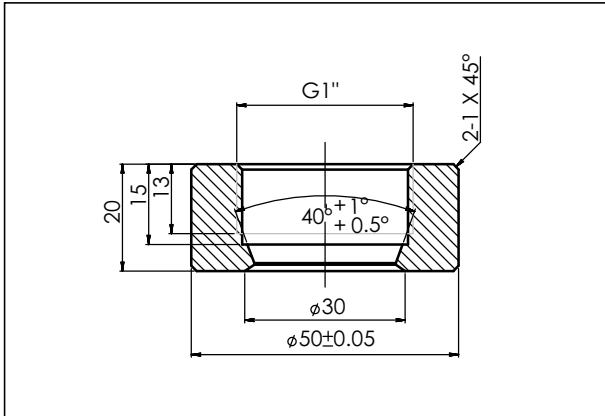

Welding accessory(H1)(unit:mm)

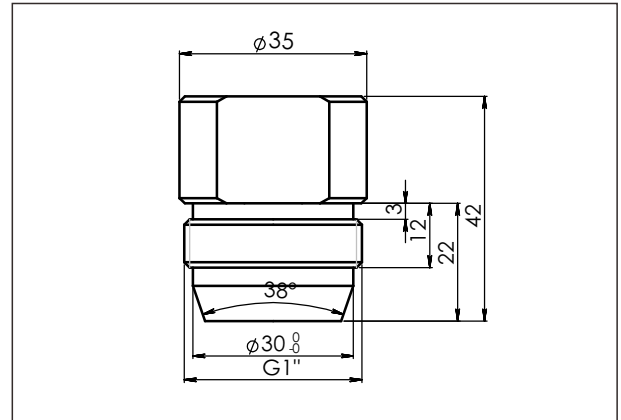

Aviation female plug straighter(J1) (unit: mm)

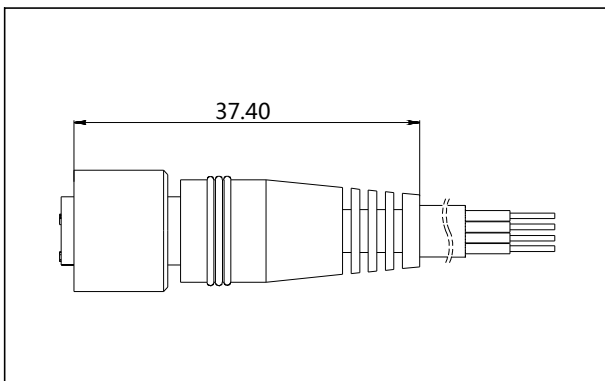

Aviation female plug elbow(J2) (unit: mm)

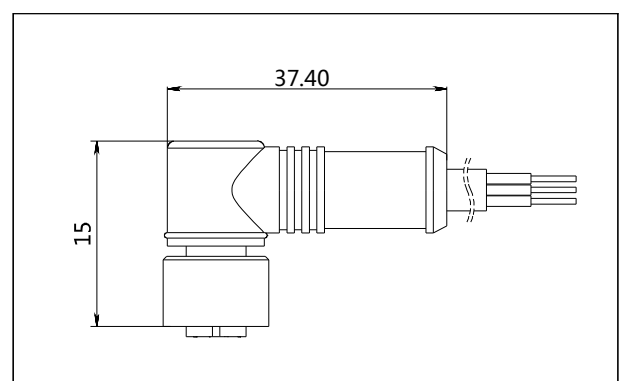

Aviation female plug straighter(J4) (unit: mm)

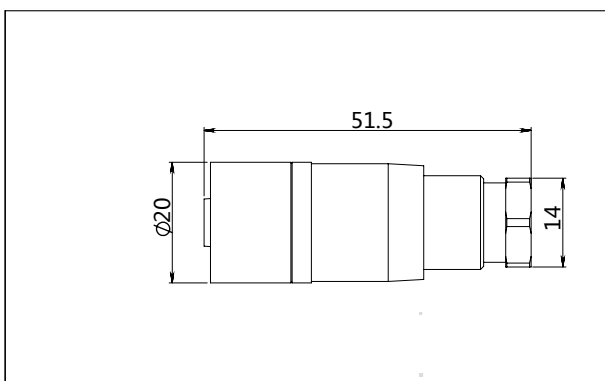

Aviation female plug elbow(J5) (unit: mm)

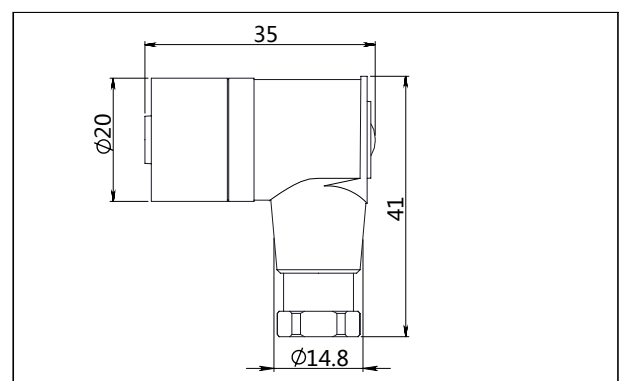

Disclaimer: all the data used in the product description is not legally binding. Relevant technical details may be changed due to further improve

**Ordering information chapter**

Item	Parameters	Code	Instruction	(*)fast delivery available
	Model	SMP858-TSF	Monosilicon gauge pressure transmitter	
Sensor	Separator	-	Detailed specifications as following	
	Pressure range code	S403G	Nominal value(URL): 40kPa	*
		S254G	Nominal value(URL): 250kPa	*
		S105G	Nominal value(URL): 1MPa	*
		S305G	Nominal value(URL): 3MPa	*
		S106G	Nominal value(URL): 10MPa	
		S406G	Nominal value(URL): 40MPa	
	Sensor seal	F	Stainless steel welding seal	*
Electrical connection	Separator	-	Detailed specifications as following	
	Electrical connection	F1	Stainless steel terminal, aviation plug M12*1 (4 pin) (H2), IP67, vertical mounting	*
		F2	Stainless steel terminal, aviation plug M12*1 (4 pin) (H2), IP67, horizontal mounting	*
	Cable entry protector	R0	None	
Output	Separator	-	Detailed specifications as following	
	Output signal	H	4-20mA+HART two wire, power supply: 16.5-55VDC	*
		F	4-20mA two wire, power supply: 10.5-55VDC	
	Display	C	LCD display	*
		A	Without LCD display	
Process connection	Separator	-	Detailed specifications as following	
	Process connector material	4	Stainless steel SUS304	
		6	Stainless steel SUS316	*
	Connection type	NT	Standard connection, medium temperature: -25-85°C	*
		HT	Cooling element connector, medium temperature: -40-150°C	
	Isolated filling fluid	F	Hygienic fluid filling, Neobee M-20, process temperature: -10-180°C	
		S	Silicon oil filling, process temperature: -45-205°C	*
	Isolated diaphragm material	S	SUS316L	*
		H	Hastelloy C	
	Process connection specifications	M01	M20*1.5(M), GB/T193-2003, ISO261, measuring range: 250kPa-40MPa	*
		G01	G1/2(M), GB/T7307,ISO228, BS2779, measuring range: 250kPa-40MPa	
		G07	G1-1/2(M), GB/T7307,ISO228, BS2779, measuring range: 10kPa-40MPa	
		G12	G1(M), metal seal GB/T7307, ISO228,BS2779, measuring range: 10kPa-10MPa	*

Ordering information chapter

Additional option	Separator	-	Detailed specifications as following	
Electrical connection accessory	/J1	/J1	Aviation female plug (straighter) with 2m cable, 4 pin, M12*1, IP67	
		/J2	Aviation female plug (elbow) with 2m cable, 4 pin, M12*1, IP67	
		/J4	Aviation female plug (straighter) without cable, 4 pin, M12*1, IP67	*
		/J5	Aviation female plug (elbow) without cable, 4 pin, M12*1, IP67	
	Process connection accessory	/Z3	Welding adaptor, M20*1.5 (F), SUS316	*
		/Z4	Welding adaptor, G1/2 (F), SUS316	
		/Z5	Welding adaptor, G1 (F), SUS316	*
	Welding accessory	/H1	Adapter plug for welding adaptor, G1 (M), material: copper	
	Calibration report	/Q1	Calibration report provided by our company	*
	Approvals (multiple)	/I1	Intrinsic safety certificate, ExiaIICT4, NEPSI (Please consult engineers for details)	*
/F3		CE certificate (Please consult engineers for details)	*	
/H1		3-A certificate (Please consult engineers for details)	*	
Wetted parts treatment	/G1	Ungrease treatment		
	/G2	Electropolishing treatment		

**Factory settings and parameters**

Item	Menu mark	Factory setting value
Tag position	None	0(No specific settings)
Analog output type	mA	Liner
Display mode	DISP	PV
Alarm signal	ALARM	No

Item	Menu mark	Factory setting value
Damping value	DAMP	0(No specific settings)
4mA Lower range value	LRV	According to the order value
20mA Upper range value	URV	According to the order value
Process unit	U	According to the order

**Approvals**

**Factory certificate**

Certificate organization	Intertek
Quality management system	ISO9001-2008
Scope of certification	Design and production of pressure transmitter
Registration number	110804039

**CE**

Certificate organization	ISET
License scope	SMP858 series pressure transmitter
Mark	CE
EMC instruction	2014/30/EU
Standard	EN61326-1: 2013
Registration number	IT051353LG161207

**Intrinsic safety certificate**

Certification organization name	NEPSI
License scope	SMP858 series pressure transmitter
Explosion-proof mark	ExialICT4
Ambient temperature	-40-+60°C
Medium maximum temperature	+120°C
Registration number	GYB16.1965X
Intrinsically safe parameter description	Maximum input voltage: 28VDC
	Maximum input current: 100mA
	Maximum input power: 0.7w
	Maximum internal equivalent parameters Ci(uF): 0
	Maximum internal equivalent parameters Li(mH): 0



scan & follow LEEG wechat



check website for more info