

Corrosion Resistance



Corrosion resistance

Appearance

Mounting	Shielded
Housing size	M18
Sensing distance	1~10mm adjustable
Detectable objects	Metal、Water、Oil、Glass、Plastic、Paper
Operating voltage	12~24V DC(Ripple < 10%)
Voltage drop	< 1.5V
Load Current, Max	100mA
Current consumption	< 22mA
Leakage current	< 1.1mA
Response time	≤ 14ms
Isolation impedance	≥ 20M Ω (500V DC)
Hysteresis	< 10% (Sr)
Insulation withstand voltage	AC 1000V 60Hz lasts 60 Sec
Operating temperature	-20℃~+60℃
Degree of protection	IP66
Connection	φ 4.2X2m 4 core cable
Weight	≈ 78g
Model No.	CWF18-10NP (NPN NO/NC PNP NC/NO)

Dimensions

Unit:mm

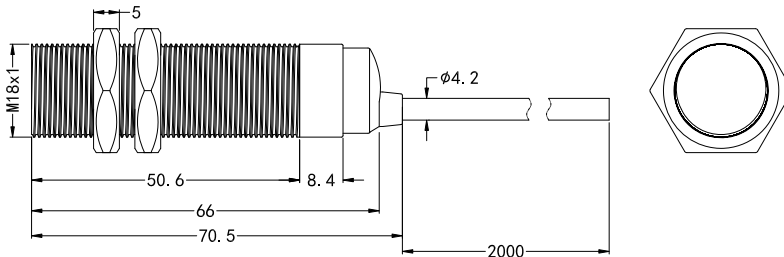

Circuit diagram

Method 1:

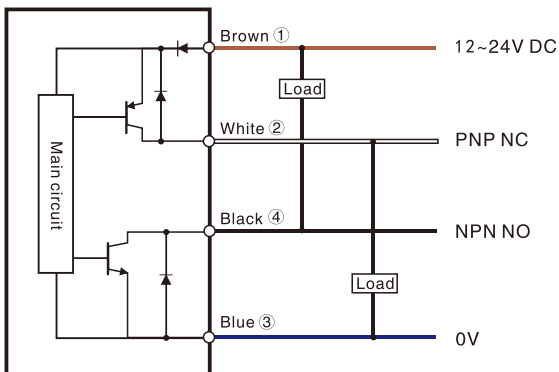

Method 2:

